

*Residential Energy Storage System*

# Power Base FC Reference Manual



Our Energy Works For You

**ZRGP**

# Table of Contents

<b>1. SafetyPrecautions</b> .....	1
1.1. General warnings.....	1
1.2. Charge and discharge warnings.....	2
1.3. Transportation warnings.....	3
1.4. Disposal of lithium batteries.....	3
1.5. Before Connecting.....	3
1.6. In Using.....	4
<b>2. Introduction</b> .....	5
2.1. Lithium iron phosphate battery.....	5
2.2. ZR-FC Features.....	5
2.3. Specifications.....	6
2.4. Equipment Interface Instruction.....	7
2.5. Sleep and wake up.....	14
2.5.1 Sleep.....	14
2.5.2 Wake up.....	14
2.6. Forced discharge mode.....	14
2.7. Automatic parallel.....	15
<b>3. How to use the ZRGP EmsTools</b> .....	16
3.1. ZRGP Ems Tools connection.....	19
<b>4. How to match communication with inverter</b> .....	20
4.1. Supported brands.....	20
4.2. Inverter matching list.....	20
4.3. Making the BMS communication cable.....	21
4.4. Connection with inverter.....	23
<b>5. Safe handling of lithium batteries guide</b> .....	24
5.1. Schematic Diagram of Solution.....	24
5.2. Familiar with batteries.....	24
5.3. Precautions before installation.....	24
5.4. Tools.....	25
5.5. Safety Gear.....	25
<b>6. Installation</b> .....	26
6.1. Package Items.....	26
6.2. Installation Location.....	24
6.3. Parallel Installation.....	24
<b>7. Wi-Fi configuration</b> .....	31
<b>8. Trouble ShootingSteps</b> .....	36
8.1 Problem determination based on.....	36
8.2 Preliminary determination steps.....	37
8.3 The battery cannot be charged or discharged.....	37
<b>9. Storage, Transportation and EmergencySituations</b> .....	38
9.1 Storage.....	38
9.2 Transportation.....	38
9.3 Emergency Situations.....	39

# 1. Safety Precautions

It is very important and necessary to read the user manual carefully (in the accessories) before installing or using battery. Failure to do so or to follow any of the instructions or warnings in this document can result in electrical shock, serious injury, or death, or can damage battery, potentially rendering it inoperable.



Observe these instructions and keep them located near the Li-ion Battery for future reference.



For more information about this product, please visit the official website:  
<http://www.zruipower.com>



Work on a Li-ion Battery should be carried out by qualified personnel only.

## 1.1. General warnings



While working on the Li-ion Battery wear protective eyeglasses and clothing.



Any uncovered battery material such as electrolyte or powder on the skin or in the eyes must be flushed with plenty of clean water immediately. Then seek medical assistance. Spillages on clothing should be rinsed out with water.



Explosion and fire hazard. Terminals of the Li-ion Battery are always alive; therefore, do not place items or tools on the Li-ion Battery. Avoid short circuits, too deep discharges, and too high charge currents. Use insulated tools. Do not wear any metallic items such as watches, bracelets, etc. In case of fire, you must use a type D, foam, or CO2 fire extinguisher.



Do not open or dismantle the battery. Electrolyte is very corrosive. In normal working conditions contact with the electrolyte is impossible. If the battery casing is damaged do not touch the exposed electrolyte or powder because it is corrosive.



Li-ion batteries are heavy. If involved in an accident, they can become a projectile! Ensure adequate and secure mounting and always use suitable handling equipment for transportation.



Handle with care because a li-ion battery is sensitive to mechanical shock.



Do not expose cable outside, all the battery terminals must be disconnected.



Do not place at a child or pet touchable area.



Do not use cleaning solvents to clean battery.



Do not expose battery to flammable or harsh chemicals or vapors.



Do not paint any part of battery; include any internal or external components.



Do not drop, deform, impact, cut or spearing with a sharp object.



Do not wet the battery and avoid of direct sunlight.



Do not use a damaged battery.



Please contact the supplier within 24 hours if there is something abnormal.



Any foreign object is prohibited to insert into any part of battery.



The warranty claims are excluded for direct or indirect damage due to items above.

## 1.2. Charge and discharge warnings



If the battery is stored for long time, it is required to charge them every six months, and the SOC should be no less than 90%.



Battery needs to be recharged within 12 hours, after fully discharged.



Do not connect battery with PV solar wiring directly.



Use only with a ZRGP approved BMS.



If charged after the Lithium Battery was discharged below the “Discharge cut-off voltage”, or when the Lithium Battery is damaged or overcharged, the Lithium Battery can release a harmful mixture of gasses such as phosphate.



The temperature range over which the battery can be charged is 0°C to 55°C. Charging the battery at temperatures outside this range may cause severe damage to the battery or reduce battery life expectancy.



The temperature range over which the battery can be discharged is -15°C to 55°C. Discharging the battery at temperatures outside this range may cause severe damage to the battery or reduce battery life expectancy.

### 1.3. Transportation warnings



The battery must be transported in its original or equivalent package and in an upright position. If the battery is in its package, use soft slings to avoid damage.



Do not stand below a battery when it is hoisted.



Never lift the battery at the terminals or the BMS communication cables, only lift the battery at the handles.

#### **NOTE:**

- Batteries are tested according to UN Handbook of Tests and Criteria, part III, sub section 38.3 (ST/SG/AC.10/11/Rev.5).
- For transport the batteries belong to the category UN3480, Class 9, Packaging Group II and must be transported according to this regulation. This means that for land and sea transport (ADR, RID & IMDG) they must be packed according to packaging instruction P903 and for air transport (IATA) according to packaging instruction P965. The original packaging complies with these instructions.

### 1.4. Disposal of lithium batteries



Batteries marked with the recycling symbol must be processed via a recognized recycling agency. By agreement, they may be returned to the manufacturer.



Batteries must not be mixed with domestic or industrial waste.



Do not throw a battery into fire.

### 1.5. Before Connecting

- ◆ After unpacking, please check product and packing list first, if product is damaged or lack of parts, please contact with the local retailer.
- ◆ Before installation, be sure to cut off the grid power and make sure the battery is in the turned-off mode.
- ◆ Wiring must be correct, do not mistake the positive and negative cables, and ensure no short circuit with the external device.
- ◆ It is prohibited to connect the battery and AC power directly.
- ◆ The embedded BMS in the battery is designed for 48VDC, please don't connect battery in series.
- ◆ Battery system must be well grounded, and the resistance must be less than 1  $\Omega$ .
- ◆ Make sure the grounding connection set correctly before operation.

- ◆ Please ensure the electrical parameters of the battery system are compatible with related equipment.
- ◆ Keep the battery away from water and fire.

## **1.6. In Using**

- ◆ If the battery system needs to be moved or repaired, the power must be cut off and the battery is completely shut down.
- ◆ It is prohibited to connect the battery with a different type of battery.
- ◆ It is prohibited to put the batteries working with a faulty or incompatible inverter.
- ◆ It is prohibited to disassemble the battery (QC tab removed or damaged).
- ◆ In case of fire, only dry powder fire extinguisher can be used, liquid fire extinguishers are prohibited.
- ◆ Please do not open, repair, or disassemble the battery except staffs from ZRGP or authorized by ZRGP. We do not undertake any consequences or related responsibility which because of violation of safety operation or violating of design, production, and equipment safety standards.

## 2. Introduction

ZR-FC series lithium iron phosphate battery is one of new energy storage products developed and produced by ZRGP, it can be used to support reliable power for various types of equipment's and systems. ZR-FC series is especially suitable for application scene of high power, limited installation space, and restricted load-bearing and long cycle life.

ZR-FC series has built-in BMS battery management system, which can manage and monitor cells information including voltage, current and temperature. What is more, BMS can help extending cycle life by balancing cells during charging and discharging.

Multiple batteries can be connected in parallel to expand capacity and power to meet the requirements of longer power supporting duration and higher power consumption.

### 2.1. Lithium iron phosphate battery

The lithium iron phosphate battery (LiFePO<sub>4</sub> or LFP) is the safest of the mainstream lithium battery types. A single LFP cell has a nominal voltage of 3.2V. A 51.2V LFP battery consists of 16 cells connected in series.

Some of LFP features are:

- ◆ Rugged - It can operate in deficit mode during long periods of time.
- ◆ High round trip efficiency.
- ◆ High energy density - More capacity with less weight and volume.
- ◆ High charge and discharge currents - Fast charge and discharges are possible.
- ◆ Flexible charge voltages.

The lithium iron phosphate battery is therefore the chemistry of choice for a range of very demanding applications.

### 2.2. ZR-FC Features

- ◆ The whole module is non-toxic, non-polluting, and environmentally friendly.
- ◆ Cathode material is made from LiFePO<sub>4</sub> with safety performance and long cycle life.
- ◆ Battery management system (BMS) has protection functions including over-discharge, over-charge, and over-current and high/low temperature.
- ◆ The system can automatically manage charge and discharge state and balance current and voltage of each cell.
- ◆ Flexible configuration, multiple battery modules can be in parallel for expanding capacity and power, up to 31 batteries in parallel.
- ◆ Adopted self-cooling mode rapidly reduced system entire noise.
- ◆ The module has less self-discharge, up to 3 months without charging it on shelf, no memory effect, excellent performance of shallow charge and discharge.
- ◆ Working temperature range is from -20 to 50°C, (Charging 0~50°C, discharging -20~50°C) with excellent discharge performance and cycle life.
- ◆ Small size and light weight, standard of 19-inch embedded designed module is easy for installation and maintenance.

## 2.3. Specifications

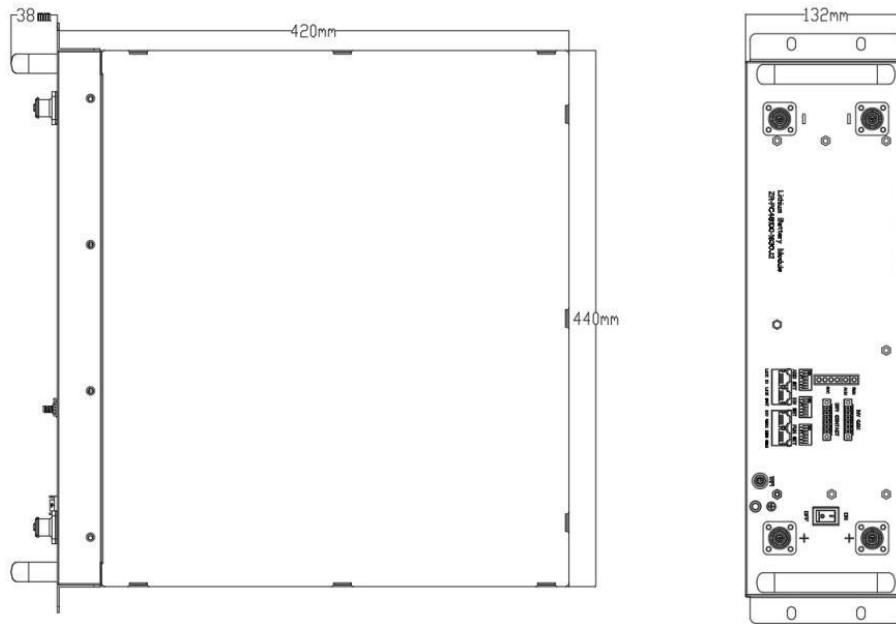

Figure 2.3. Outline dimensional drawing

NO.	Items	ZR-FC48100-1630J2 / ZR-FC4810-1630J2-H
1	Cell Model	100Ah/3.2V
2	Compound Mode	1P16S
3	Rated Capacity	100Ah
4	Rated Energy	5120Wh
5	Initial Resistance	<50mΩ
6	Nominal Voltage	51.2V
7	Charge Cut-off Voltage	59.2V
8	Discharge Cut-off Voltage	43.2V
9	Rated Charging Current	20A
10	Maximum Charging Current	95A
11	Rated Discharge Current	50A
12	Maximum Discharge Current	95A
13	Heating Film Resistance(Ω)	16 (-H model only)
	Heating Start Temperature (°F/°C)	41/5 (-H model only)
15	Charging Temperature	-0~+50°C
16	Discharge Temperature	-20~+50°C
17	Shell Type	Painted metal
18	Weight	45±1Kg
19	Size	420(L)*440(W)*132(H)mm



## 2.4. Equipment Interface Instruction

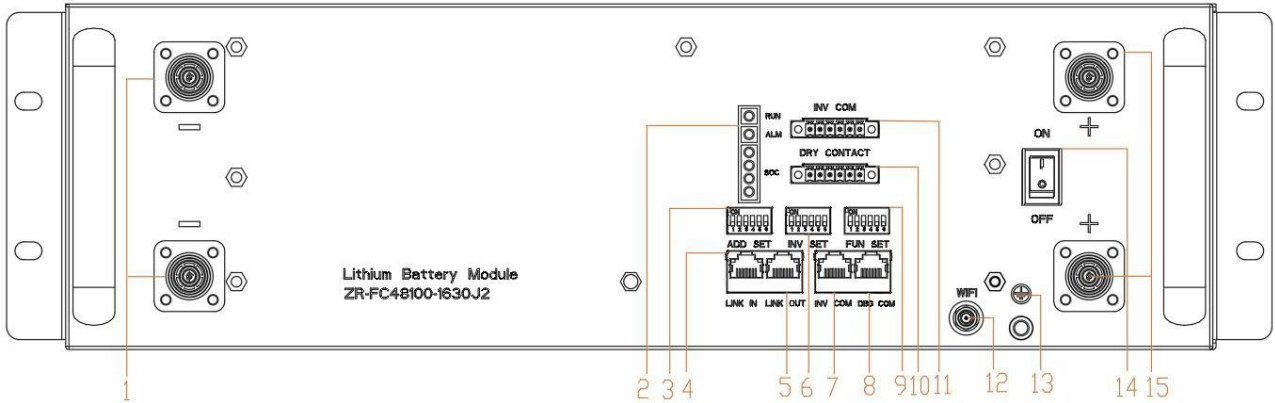

Figure 2.4. Interface definition

NO.	Instructions	NO.	Instructions
1	DC power negative	9	FUN SET: Function dial switch
2	Status indicator	10	Dry contact: Reserved
3	Address dial switch	11	INV. COM
4	LINK IN (Multi-device parallel connection)	12	Wi-Fi port
5	LINK OUT (Multi-device parallel connection)	13	GND
6	INV.SET: Inverter dial switch	14	ON/OFF button
7	INV.COM: Inverter interface	15	DC power positive
8	DEBUG interface port		

### ON/OFF button

Power switch: to turn ON/OFF the battery. When it is off, BMS standby, no power output.

### Dry contact

Dry contact: provided 2 ways output dry contact signal.

### Address dial switch

ADD Switch: 6 ADD switches, “0” and “1”, refer to picture right. The settings will be active only after restart the battery.

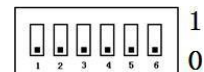

When the battery communicates with the inverter, the address of the battery pack must be set to 1, and the address of the parallel slave should be greater than 1.

When the battery pack is connected in parallel, cascading communication is required. Hardware address configuration is required for both the master pack and the slave pack, and the hardware address can be set by the dial switch on the board. The definition of the switch refers to the table below.

Address Coding	Dial Code Switch Position						Definition
	#1	#2	#3	#4	#5	#6	
1	ON	OFF	OFF	OFF	OFF	OFF	Set the master pack, and the inverter communicates with the battery at that address
2	OFF	ON	OFF	OFF	OFF	OFF	Set to the slave Pack 1
3	ON	ON	OFF	OFF	OFF	OFF	Set to the slave Pack 2
4	OFF	OFF	ON	OFF	OFF	OFF	Set to the slave Pack 3
5	ON	OFF	ON	OFF	OFF	OFF	Set to the slave Pack 4
6	OFF	ON	ON	OFF	OFF	OFF	Set to the slave Pack 5
7	ON	ON	ON	OFF	OFF	OFF	Set to the slave Pack 6
8	OFF	OFF	OFF	ON	OFF	OFF	Set to the slave Pack 7
9	ON	OFF	OFF	ON	OFF	OFF	Set to the slave Pack 8
10	OFF	ON	OFF	ON	OFF	OFF	Set to the slave Pack 9
11	ON	ON	OFF	ON	OFF	OFF	Set to the slave Pack 10
12	OFF	OFF	ON	ON	OFF	OFF	Set to the slave Pack 11
13	ON	OFF	ON	ON	OFF	OFF	Set to the slave Pack 12
14	OFF	ON	ON	ON	OFF	OFF	Set to the slave Pack 13
15	ON	ON	ON	ON	OFF	OFF	Set to the slave Pack 14
16	OFF	OFF	OFF	OFF	ON	OFF	Set to the slave Pack 15
17	ON	OFF	OFF	OFF	ON	OFF	Set to the slave Pack 16
18	OFF	ON	OFF	OFF	ON	OFF	Set to the slave Pack 17
19	ON	ON	OFF	OFF	ON	OFF	Set to the slave Pack 18
20	OFF	OFF	ON	OFF	ON	OFF	Set to the slave Pack 19
21	ON	OFF	ON	OFF	ON	OFF	Set to the slave Pack 20
22	OFF	ON	ON	OFF	ON	OFF	Set to the slave Pack 21
23	ON	ON	ON	OFF	ON	OFF	Set to the slave Pack 22
24	OFF	OFF	OFF	ON	ON	OFF	Set to the slave Pack 23
25	ON	OFF	OFF	ON	ON	OFF	Set to the slave Pack 24
26	OFF	ON	OFF	ON	ON	OFF	Set to the slave Pack 25
27	ON	ON	OFF	ON	ON	OFF	Set to the slave Pack 26
28	OFF	OFF	ON	ON	ON	OFF	Set to the slave Pack 27
29	ON	OFF	ON	ON	ON	OFF	Set to the slave Pack 28
30	OFF	ON	ON	ON	ON	OFF	Set to the slave Pack 29
31	ON	ON	ON	ON	ON	OFF	Set to the slave Pack 30

### FUN.SET

Function Switch: Six dial codes, “0” and “1”, refer to picture right.

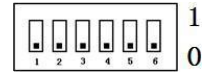

① in the case of a single machine, all dip switches must be dialed 0.

② for parallel use, use dip switch to set the address: The first and last two need to be set as 000001, the middle battery is set as 000000.

③ when EMSTOOLS is used to automatically set the address: the first dial 100001, the middle dial 000000, the last set of dial 010001. In this case the dip switch is invalid.

### INV.SET

ADD Switch: Six dial codes, “0” and “1”, refer to picture right.

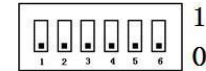

When the host relates to the inverter, the host computer needs to communicate. Hardware address configuration is required on the host, and the hardware address can be set through the dial switch on the board.

Inverter protocol setting function of dial switch 0 ~ 31: The inverter communication protocol can be changed directly by setting the dial switch, the definitions are shown in the following table.

Address Coding	Dial Code Switch Position						Definition
	#1	#2	#3	#4	#5	#6	
0	OFF	OFF	OFF	OFF	OFF	OFF	Monitoring Software setting mode
1	ON	OFF	OFF	OFF	OFF	OFF	ZRGP
2	OFF	ON	OFF	OFF	OFF	OFF	Studer_Xtender
3	ON	ON	OFF	OFF	OFF	OFF	Sofar_LV
4	OFF	OFF	ON	OFF	OFF	OFF	Solis_LV
5	ON	OFF	ON	OFF	OFF	OFF	Goodwe_LV
6	OFF	ON	ON	OFF	OFF	OFF	Victron_color control
7	ON	ON	ON	OFF	OFF	OFF	SMA_LV
8	OFF	OFF	OFF	ON	OFF	OFF	Sermatec_LV
9	ON	OFF	OFF	ON	OFF	OFF	Reserved
10	OFF	ON	OFF	ON	OFF	OFF	Growatt_SPF
11	ON	ON	OFF	ON	OFF	OFF	Li_PLUS
12	OFF	OFF	ON	ON	OFF	OFF	Schneider_Gateway
13	ON	OFF	ON	ON	OFF	OFF	SOL-ARK_LV
14	OFF	ON	ON	ON	OFF	OFF	Phocos-AnyGrid

15	ON	ON	ON	ON	OFF	OFF	AFORE-LV
16	OFF	OFF	OFF	OFF	ON	OFF	Voltronic Power
17	ON	OFF	OFF	OFF	ON	OFF	DEYE
18	OFF	ON	OFF	OFF	ON	OFF	Growatt_SPH
19	ON	ON	OFF	OFF	ON	OFF	Reserved
20	OFF	OFF	ON	OFF	ON	OFF	Reserved
21	ON	OFF	ON	OFF	ON	OFF	SAJ-LV
22	OFF	ON	ON	OFF	ON	OFF	SMA-LV
23	ON	ON	ON	OFF	ON	OFF	Reserved
24	OFF	OFF	OFF	ON	ON	OFF	Fronius
25	ON	OFF	OFF	ON	ON	OFF	Lux
26	OFF	ON	OFF	ON	ON	OFF	Reserved
27	ON	ON	OFF	ON	ON	OFF	GreenCell
28	OFF	OFF	ON	ON	ON	OFF	Reserved
29	ON	OFF	ON	ON	ON	OFF	Must
30	OFF	ON	ON	ON	ON	OFF	MEGAREVO-LV
31	ON	ON	ON	ON	ON	OFF	Aiswei-LV

### DEBUG port

The device supply CAN communication connection, for manufacturers or professional engineers debugging or service.

Port definitions	RJ11 Pin	Function
 <p><b>DEBUG</b></p>	1	Parallel.CANL
	2	Parallel.CANH
	3	GND
	4	CANG
	5	CANG
	6	GND
	7	CANL
	8	CANH

**INV.COM**

Device supply inverter communication connection: RS485 & CAN Interface. CAN/RS485 communication port: (RJ45 port) follow CAN protocol and RS485 protocol, for output batteries information, the battery uses this interface to communicate with external inverters, PCS, and other devices.

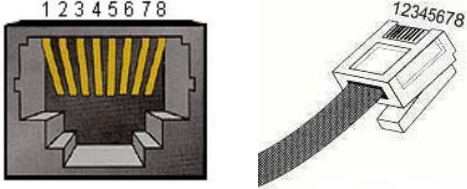
Port definitions	RJ45 Pin	Function
	1	RS485-B
	2	RS485-A
	3	RS485-GND
	4	CAN-GND
	5	CAN-GND
	6	RS485-GND
	7	CANH
	8	CANL

**Battery anode and Battery cathode**

Battery anode and battery cathode: there are two pair of terminals with same function, one connects to equipment, the other one paralleling to other battery module for capacity expanding. For each single module, each terminal can achieve charging and discharging function. For power cables uses water-proofed connectors. It must keep pressing this Lock Button while pulling out the power plug.

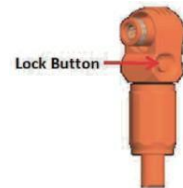

**Function features**

- a. Alarm indicator: Red LED flashing to show the battery has alarm, and always-on to show the SOC indicator: Indicates SOC status and charging status.
- b. Alarm indicator: Indicating fault status.
- c. Run indicator: Indicates the network status.

**Table 1 LED ALM working state indication**

State	Normal protect	ALM	Indicate
		●	
Shutdown	Power down	OFF	All off
Standby	Normal	OFF	Standby
	Warning	Flash 3*	Low voltage
Charging	Normal	OFF	Overcharge alarm ALM light does not flash
	Warning	Flash 3*	
	Protect	Flash 2*	Stop charging
	Temperature, overcurrent, failure protection	ON	Stop charging
Discharging	Normal	OFF	\
	Warning	Flash 3*	
	Protect	Flash 2*	Stop discharging
	Temperature, overcurrent, Short, failure protection	ON	Stop discharging
Failure	Failure	ON	Stop charging and discharging
Parallel	Address >1 and not connected	\	The slave waits for a parallel state

\*See the definition for Flash 1/2/3 on the following page.

**Table 2 Capacity Indication**

State	Charging				Standby/Discharging				
	L4 ●	L3 ●	L2 ●	L1 ●	L4 ●	L3 ●	L2 ●	L1 ●	
Capacity indication light	L4 ●	L3 ●	L2 ●	L1 ●	L4 ●	L3 ●	L2 ●	L1 ●	
Capacity (%)	0%	OFF	OFF	OFF	Flash 2	OFF	OFF	OFF	OFF
	0 ~ 25%	OFF	OFF	OFF	Flash 2	OFF	OFF	OFF	ON
	25 ~ 50%	OFF	OFF	Flash 2	ON	OFF	OFF	ON	ON
	50 ~ 75%	OFF	Flash 2	ON	ON	OFF	ON	ON	ON
	75 ~ 100%	Flash 2	ON	ON	ON	ON	ON	ON	ON

**Table 3 LED Wi-Fi status instructions**

State	Running state
The network status	Run ●
Wi-Fi is not connected to the router	On
Wi-Fi is connected to the router	Flash 2
Wi-Fi connection to the cloud platform	Flash 3

**Table 4 LED flashing instructions**

Flashing way	ON	OFF
Flash 1	0.25S	3.75S
Flash 2	0.5S	0.5S
Flash 3	0.5S	1.5S

## 2.5. Sleep and wake up

### 2.5.1 Sleep

When any of the following conditions is met, the battery enters the low-power mode:

- (1) Under voltage protection is not released within 30 seconds.
- (2) The lowest cell voltage is lower than the sleep voltage, and the duration reaches the sleep delay time (while meeting the requirements of no communication, no protection, no equilibrium, and no current).
- (3) Standby mode lasts for more than 24 hours (no communication, no charge and discharge, no mains power, minimum cell is less than 3.2V).
- (4) Forced shutdown from the ZRGP EmsTools.

Before entering sleep, make sure no charger is connected, otherwise, it will not be able to enter low-power mode.

### 2.5.2 Wake up

When the system is in the low-power mode and any of the following conditions is satisfied, the system will exit the low-power mode and enter the normal operation mode:

- (1) Connect the charger, and the output voltage of the charger must be greater than 48V.
- (2) Connect the communication line and open the ZRGP EmsTools (if enters sleep mode due to over-release protection, and this method cannot wake up the battery).
- (3) Use the power software switch.

#### **NOTE:**

• After battery over-discharge protection, it enters the low-power mode, wakes up at a regular time every 4 hours, and starts open switch to charging or discharging. If it can be charged, it will exit the sleep mode and enter the normal charging state. If the auto wakes up fails to charge for 10 consecutive times, it will no longer auto wake up. When the system is defined as the end of charging, and the recovery voltage is still not reached after 2 days /48h standby time (standby time set value), it is forced to resume charging until the end of recharging.

## 2.6. Forced discharge mode

When the battery is in the sleep mode by under voltage protect and the lowest cell is greater than 2.0V, first close the power switch, and then wait for 2s before turning on the power switch, and the battery enters the forced discharge mode for 5 minutes. In the forced discharge mode, if there is a charge, the battery will exit the forced discharge mode and switch to the normal mode. If the discharge current exceeds 20A or there is no charge current within 5 minutes, the battery will re-enter the sleep mode.



## 2.7. Automatic parallel

With automatic parallel function, when the slave battery (address > 1) is powered on, the charge and discharge switch is in disconnect state. When the voltage difference between the slave battery and master battery is less than the condition of "the minimum voltage difference between the slave and the master", the master sends the command to the slave. After the slave receives the command from the master, the charge and discharge switch will be connected, and the slave is integrated into the master system to complete the parallel operation.

## 3. How to use the ZRGP EmsTools

### 3.1. ZRGP Ems Tools connection

- (1) Connect the Debug com part of the battery to the computer using the CAN box communication line (this accessory is an optional accessory, need to be purchased separately from the manufacturer).
- (2) Unzip the package file of the Monitoring Software Ems Tools in the same file directory, pay attention to the directory do not store other files.



Figure 3.1.1. Unzip of Monitoring Software EmsTools

- (3) This software is based on LabVIEW platform. Before opening EMS, you need to install a lab software, then open the Monitoring Software Ems tools icon, enter the Protocol selection interface.

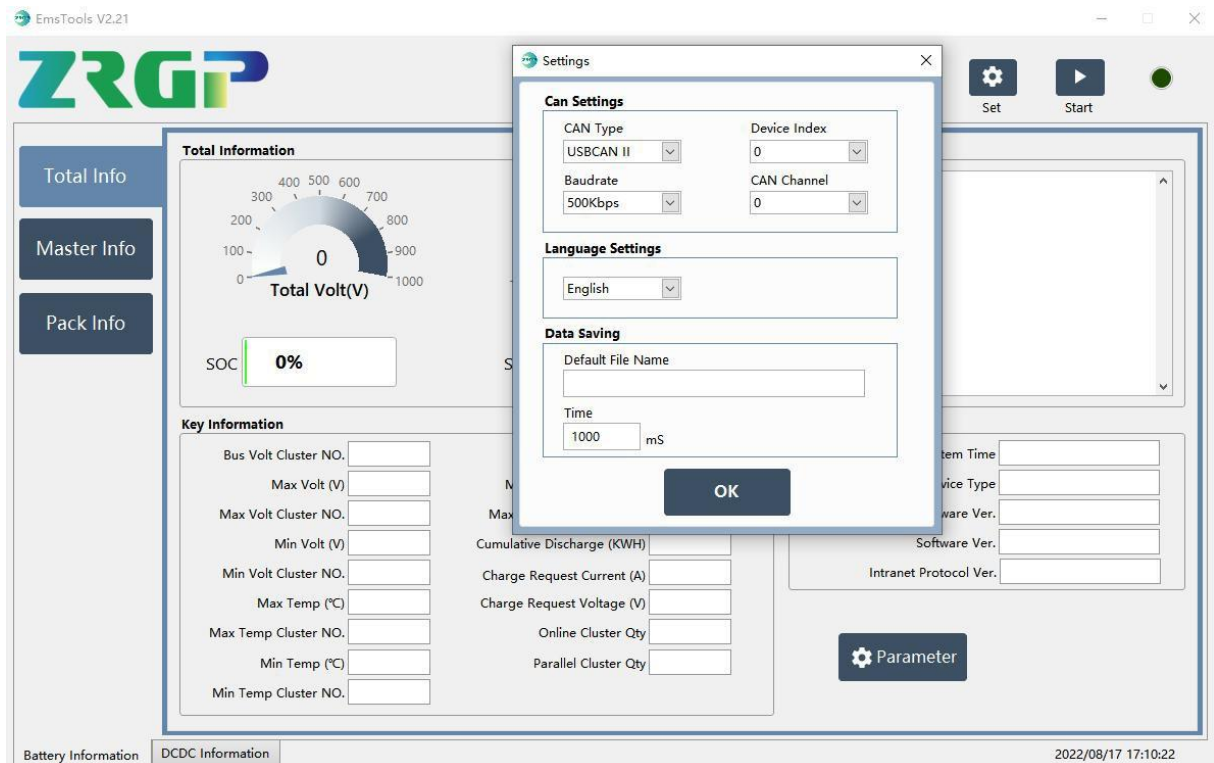

Figure 3.1.2. Protocol selection interface

- (4) Users can set different languages according to their own needs. We support two languages, which are Simplified Chinese, and English.

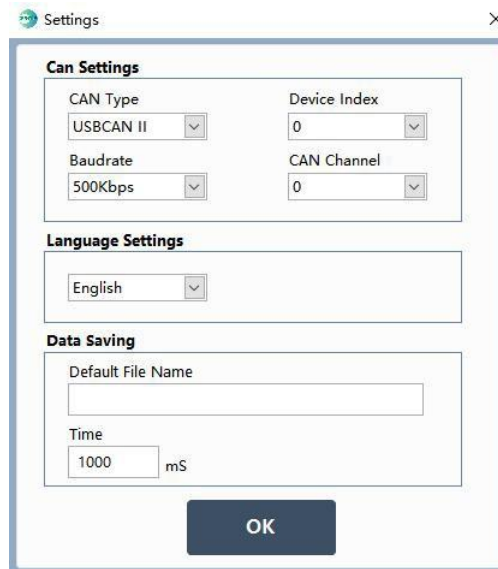

Figure 3.1.3. Monitoring software EMS language selection

(5) Select the serial port number in the EMS version of the Monitoring Software EMS tool, and the default baud rate is 500. Click the OK buttons.

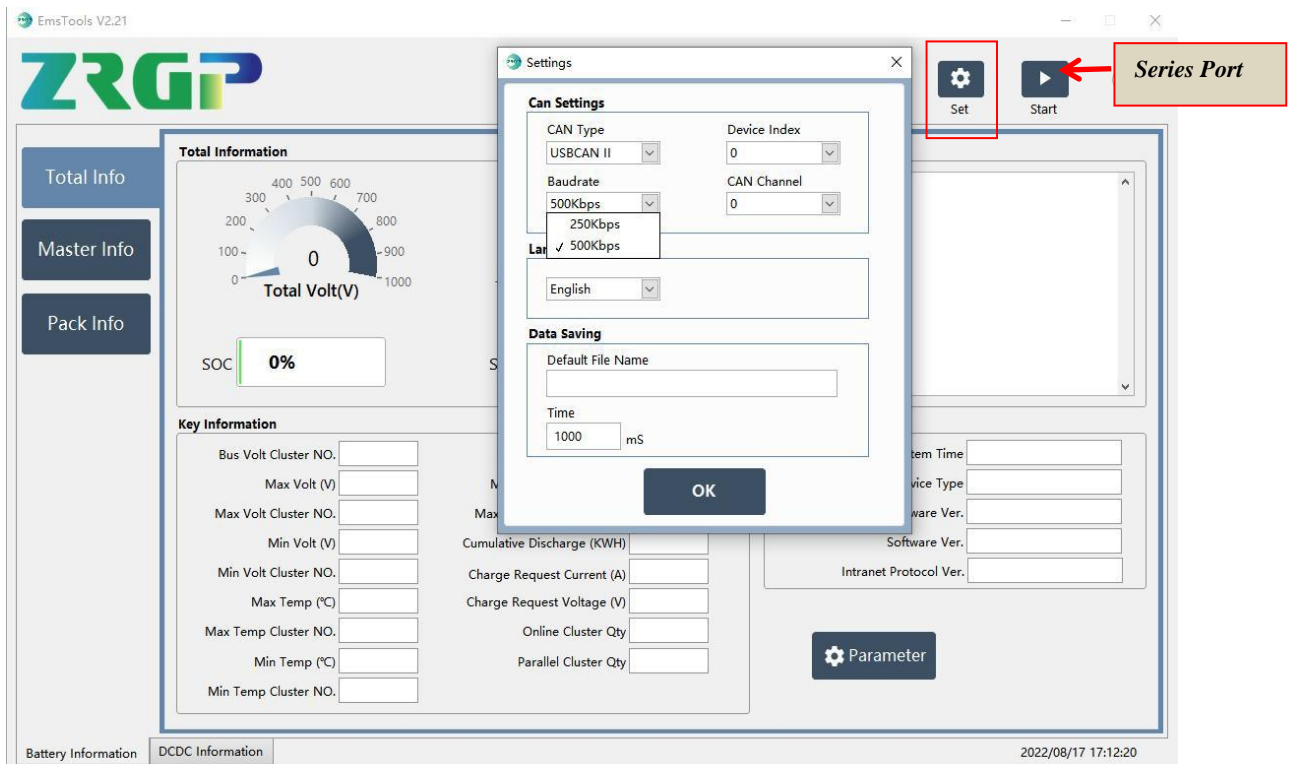

Figure 3.1.4. Monitoring software EMS serial port settings

(6) The corresponding functions can be selected through the navigation bar of the Monitoring Software EMS.

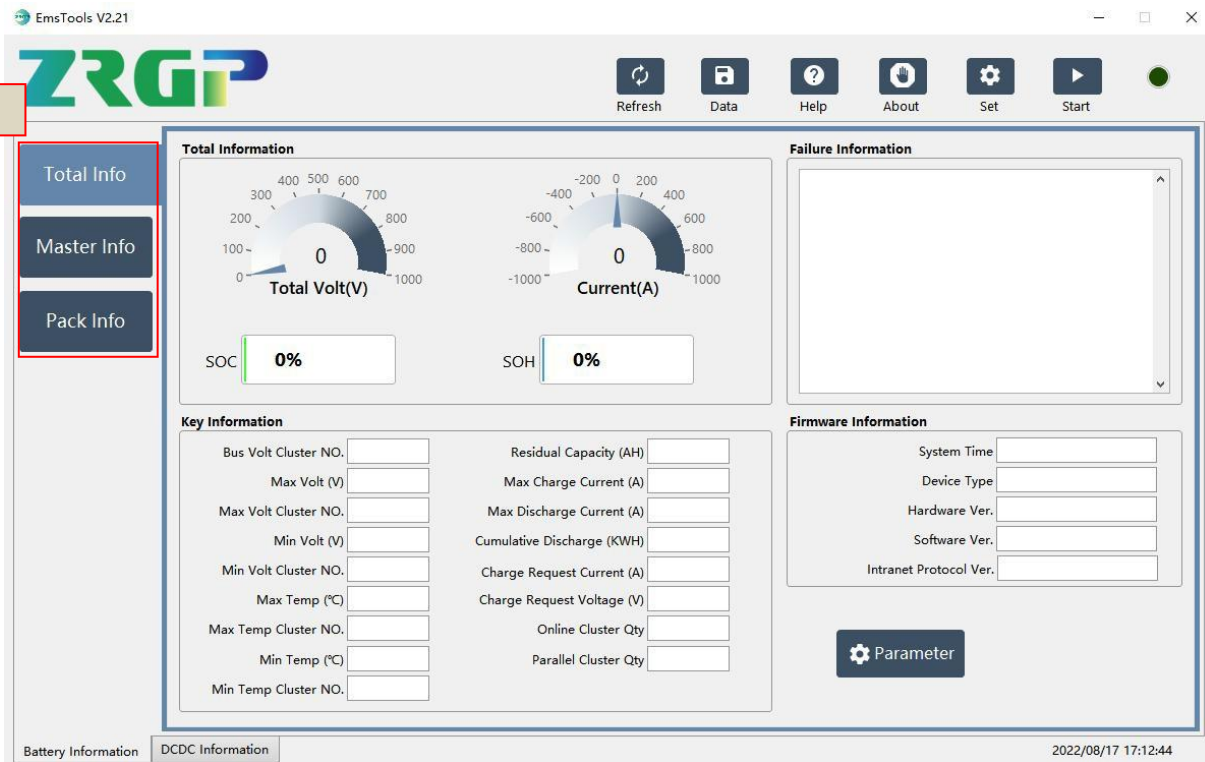

Figure 3.1.5. Monitoring software EMS data acquisition

(7) Cluster information operation information, You can select the corresponding operation information through the navigation bar. A total of 15 clusters can be monitored.

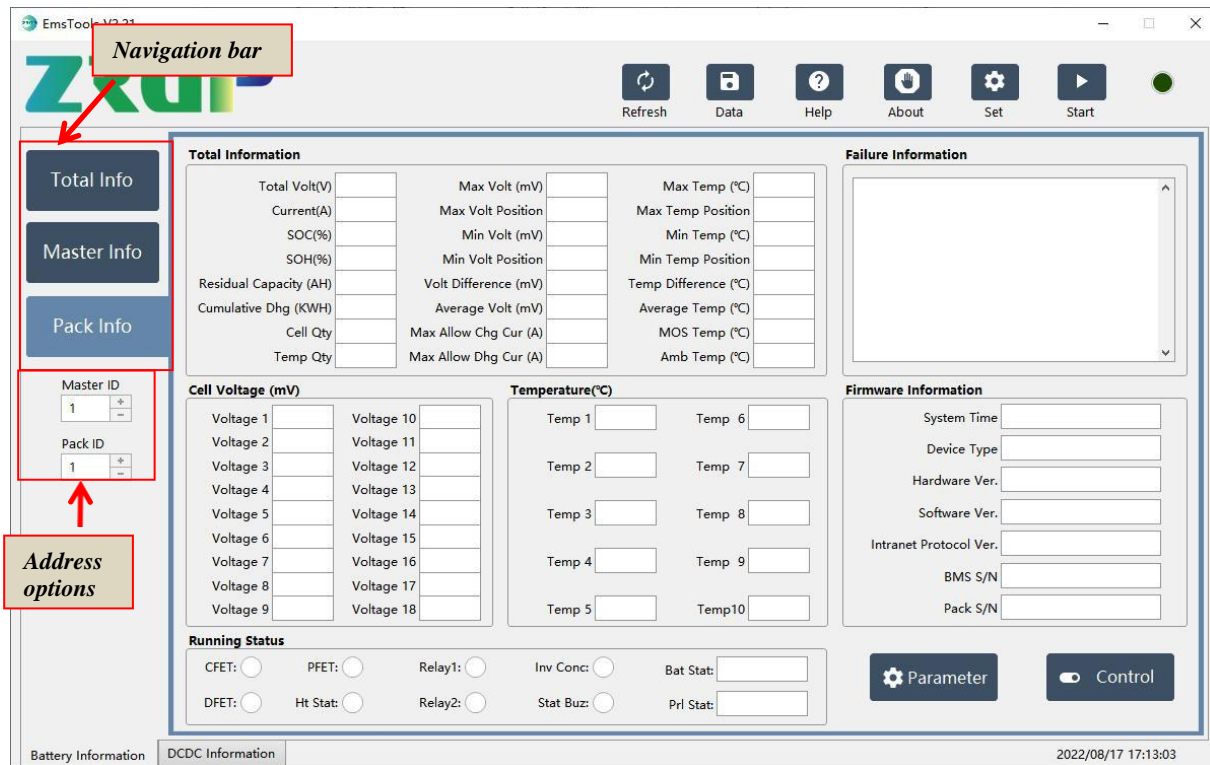

Figure 3.1.6. Monitoring software cluster data acquisition

(8) The configuration parameter interface displays software version, hardware version, temperature quantity and module battery quantity of a cluster in real time.

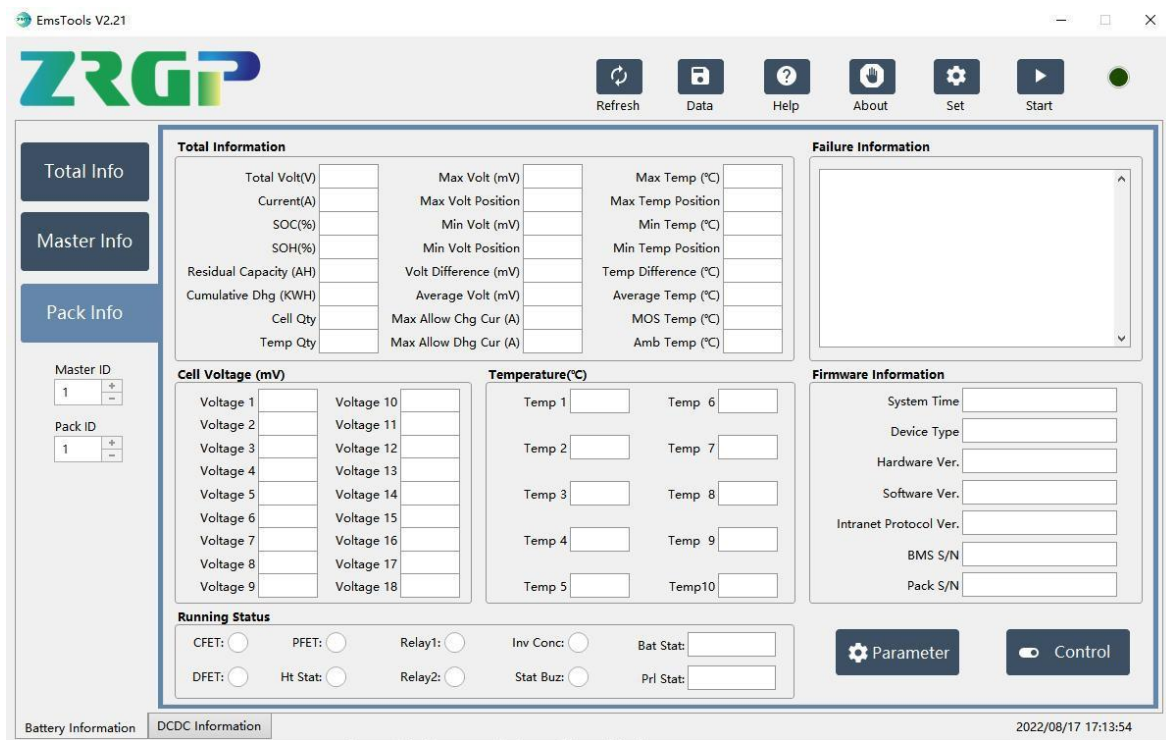

Figure 3.1.7. Monitoring software cluster matching parameters

**NOTE:**

- The above contents only show the basic functions and operations of the monitoring software EMS tool. If you encounter any problems, please contact the supplier for solution.

## 4. How to match communication with inverter

### 4.1. Supported brands

At present, the energy storage products of our company have completed matching tests with some series inverters of the following brands, and we will continue matching tests with inverters of other companies. Please check our official website for the latest list of supporting brands. <http://www.zruipower.com>.

POWER BASE LV-MATE Compatible Inverter List



POWER BASE HV-MATE Compatible Inverter List



### 4.2. Inverter matching list

The list tab only lists the inverter manufacturers one of the same series products, general inverter manufacturers in the same series of other products, the communication protocol are the same, so our battery can be communicated with the other products of same series inverter, if encounter a series of products can't communication, please contact us.

The following inverter matching list may not be up to date. The list may change according to the software version upgrade, and the reference manual may does not change immediately according to the software version upgrade. Therefore, if the user wants to get the latest inverter matching support, please browse the official website to check the relevant documents, <http://www.zruipower.com>.

The inverter manufacturer may upgrade its software version, which may cause problems in the communication between our battery and the inverter. Therefore, before communicating with the inverter, please confirm whether the software version of the inverter is consistent with the list. If not, please contact us.

### 4.3. Making the BMS communication cable

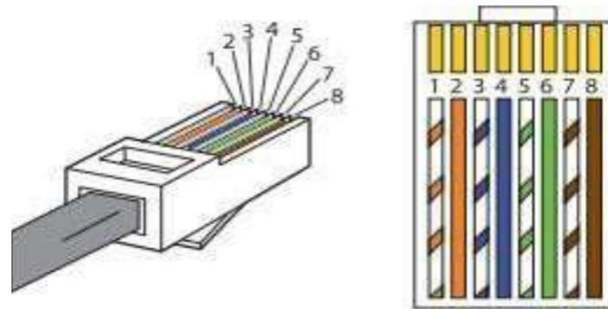

- (1) Cut network cable to the needed length.
- (2) Strip 2.5 to 5 cm of the outer sheath at one end of the cable.
- (3) Untwist and separate each pair of wires.
- (4) Arrange the wires in this order.
- (5) Keep only the cables you need.
- (6) Bring the sorted wires together and trim them to about 1.4 cm in length.
- (7) Hold the RJ45 plug with the copper contacts facing up, and insert the wires into the plug, making sure that they stay aligned and each color goes into its appropriate channel.
- (8) Put the plug into a cable crimper and squeeze the handles thoroughly.

## 4.4. Connection with inverter

This section will introduce how to hardware connect ZR-FC series products with the 8.2 section “Inverter Matching List”. Inverters manufacturers may upgrade their products, resulting in hardware communication interface changes. If communication is not possible in the application according to the following wiring method, please contact with us.

The CAN/RS485 communication port of ZR-FC relates to the communication interface of inverter.

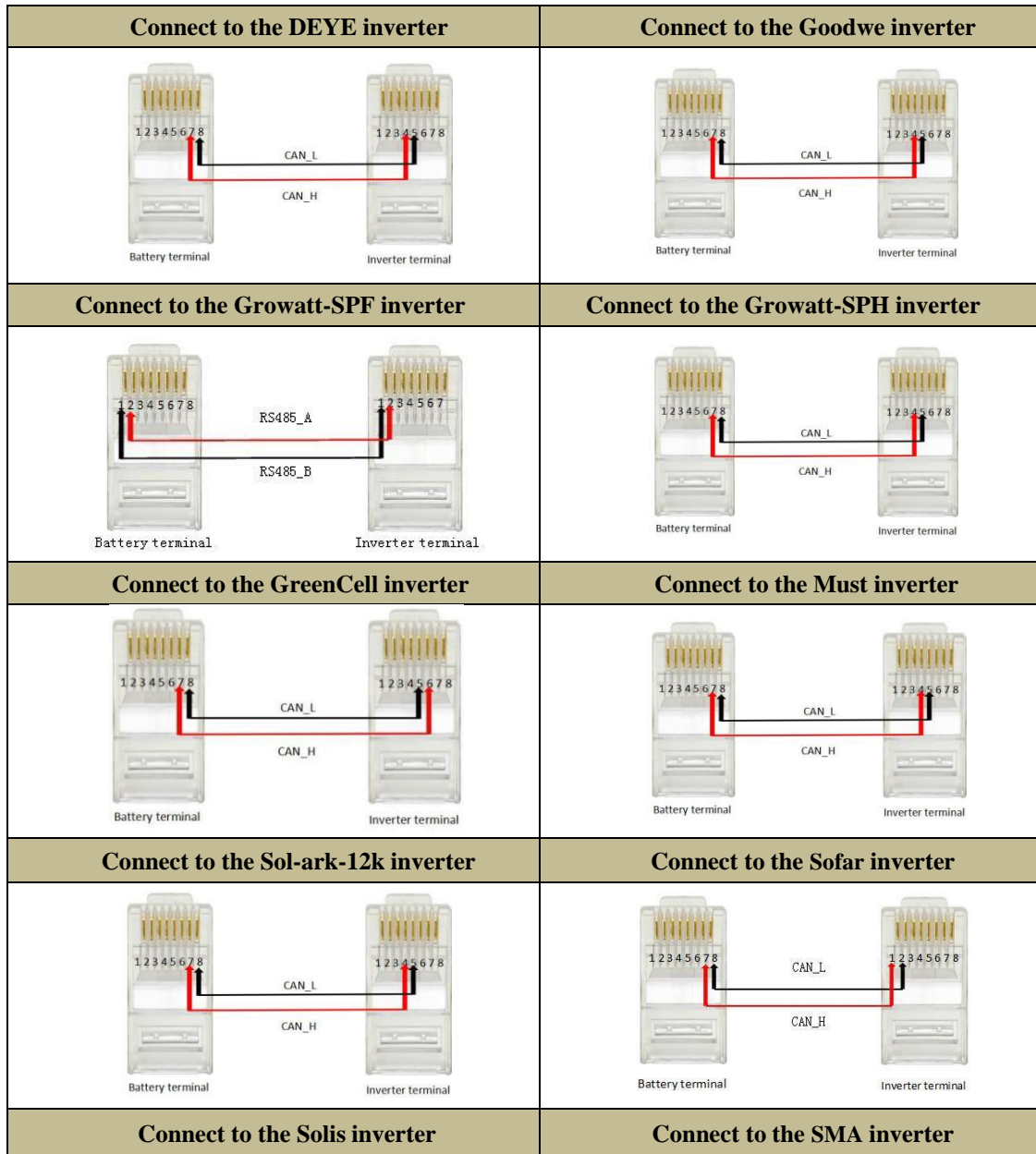



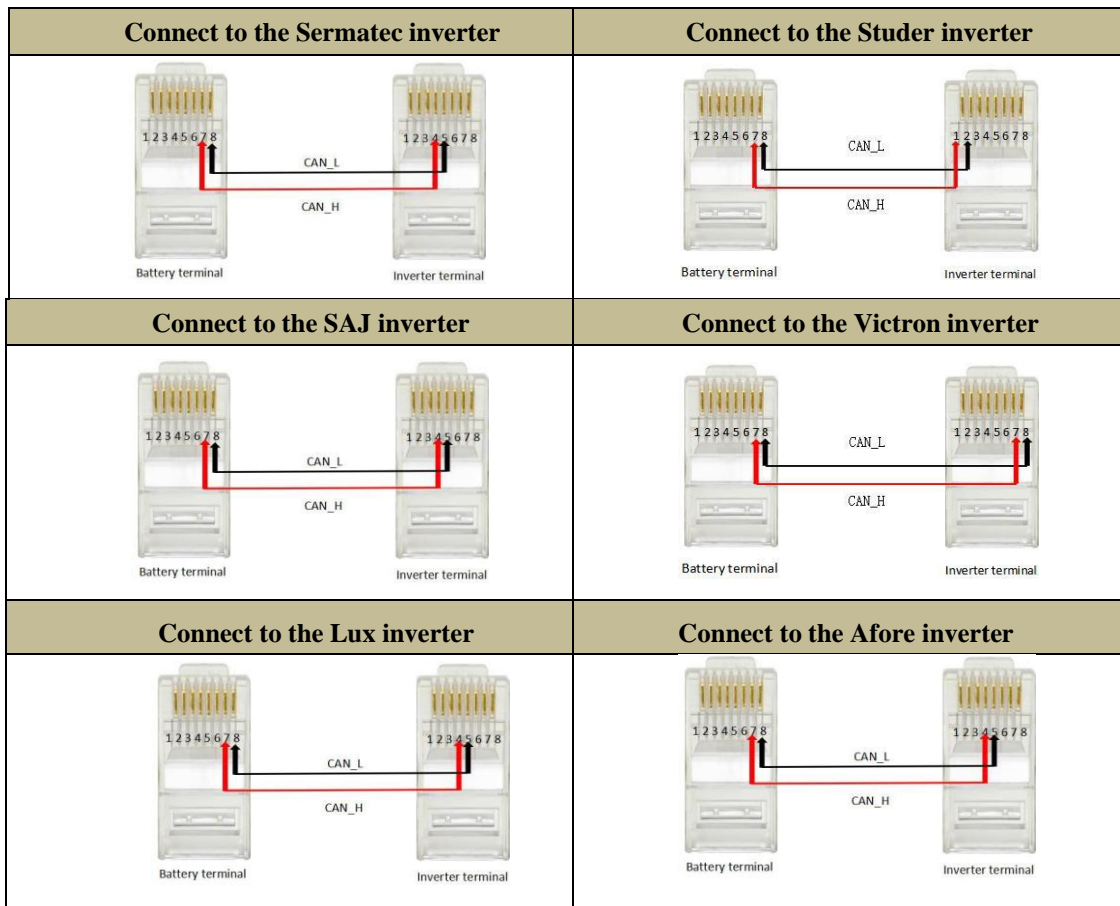

a. If you are using the pin order select box, please refer to the table above to set the dial switch, according to the inverter brand.

b. For example, if you want to match a Deye inverter, you should dial 4 high and 5 low on the CAN side as shown in the following figure.

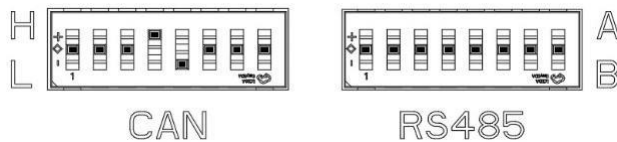

c. If the inverter brand is not shown in the table, please refer to the inverter manual or consult ZRGP's engineer.

**NOTE:**

- The above CAN and RS485 communication connections are not connected the ground wire, in the application of relatively large interference, it is recommended to connect the ground wire, the ground wire connection method is a single-ended shielding line.
- If you want to view inverter matching and dip details, please visit our website <https://zruipower.com/wp-content/uploads/2023/09/Inverter-Matching-Guide-ZRGP-battery1.pdf>.

## 5. Safe handling of lithium batteries guide

### 5.1. Schematic Diagram of Solution

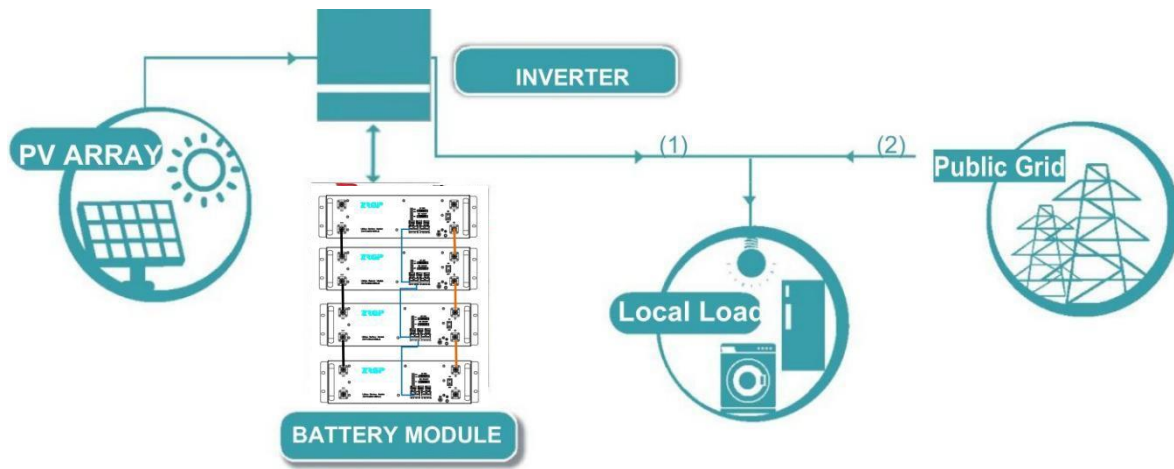

Figure 5.1. Schematic diagram of solution

### 5.2. Familiar with batteries

Be careful when opening the battery package. The battery is heavy. Do not lift it with a pole. There are two handles on both sides of the battery. The weight of the battery can be found in the chapter "Specifications".

Familiar with batteries. The battery polarity is displayed on both sides of the battery. The positive pole is represented by "+" and the negative pole by "-".

### 5.3. Precautions before installation

Before installation, be sure to read the contents in Chapter 1 Safety Precautions, which is related to the operation Safety of installation personnel, please pay attention to.

### 5.4. Tools

The following tools are required to install the battery pack:



Wire cutter



Crimping Modular Pliers



Screwdriver

**NOTE:**

• Use properly insulated tools to prevent accidental electric shock or short circuits. If insulated tools are not available, cover the entire exposed metal surfaces of the available tools, except their tips, with electrical tape.

### 5.5. Safety Gear

It is recommended to wear the following safety gear when dealing with the battery pack:



Insulated gloves



Safety goggles



Safety shoes







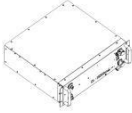

## 6. Installation

### 6.1.Package Items

Unpacking and check the Packing List:

(1) Packing list:

After receiving the complete system, please check to ensure that all the following component are not lost or damaged broken.

 Whole machine system×1	 Connector*2(orange and black)	 UL1015, 4 AWG, Red and black cable
 Pin order select box (optional)	 Communication cable RJ45(1m)	 User's manual
 Antenna	 Class six network cable(250mm)	 trestle

(2) Connector:

Each battery will be equipped with a positive connector and a negative connector, the two connectors are not connected to the cable, and the user can be wired according to the actual application needs.



Positive connector



Negative connector

(3) Connector For battery module package:

Two long power cables (current capacity 120A) and one communication cable for each battery package (1800mm):

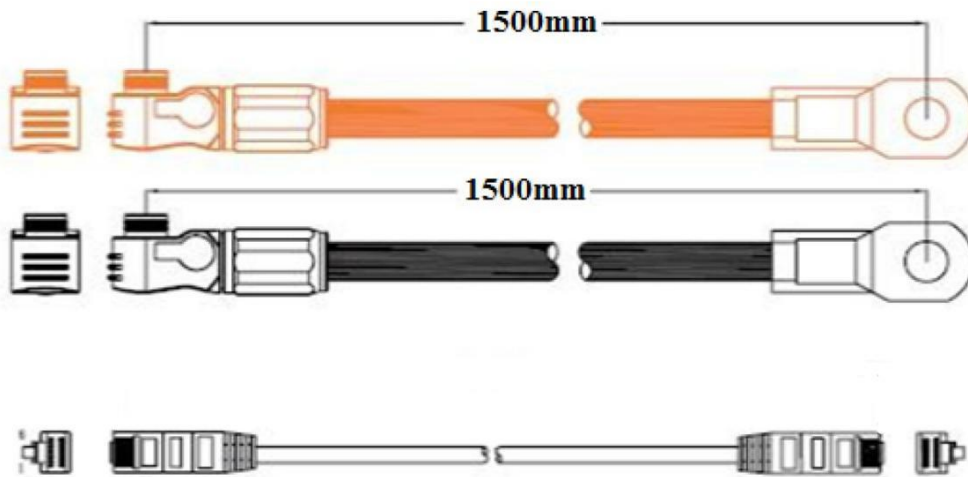

(4) Grounding:

ZR-FC modules' grounding is based on metal directly touch between the module's surface and rack's surface. So, it needn't grounding cables at all. If uses normal rack, it can remove the paint at the corresponding place, or install a grounding cable to the grounding point of the modules.

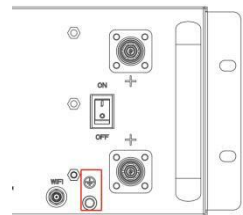

(5) Pin order select box (optional):

Set the pin order of the communication cable of battery and inverter, cooperate with 2 standard network cable.



## 6.2. Installation Location

Make sure that the installation location meets the following conditions:

- ◆ The area is completely waterproof.
- ◆ The floor is flat and level.
- ◆ There are no flammable or explosive materials.
- ◆ The ambient temperature is within the range from 0°C to 50°C.
- ◆ The temperature and humidity are maintained at a constant level.
- ◆ There is minimal dust and dirt in the area.
- ◆ The distance from heat source is more than 2 meters
- ◆ The distance from air outlet of inverter is more than 0.5 meters.
- ◆ Do not install outside directly.
- ◆ Do not cover or wrap the battery case or cabinet.
- ◆ Do not place at a child or pet touchable area.
- ◆ The installation area shall avoid of direct sunlight.
- ◆ There are no mandatory ventilation requirements for battery module, but please avoid of installation in confined area. The aeration shall avoid of high salinity, humidity, or temperature.
- ◆ ADC isolator is recommended to be add on the power circuit between inverter and battery, recommended rating at 120Amps per set of external power cable.



### CAUTION

If the ambient temperature is outside the operating range, the battery pack stops operating to protect itself. The optimal temperature range for the battery pack to operate is 0°C to 50°C. Frequent exposure, to harsh temperatures may deteriorate the performance and life of the battery pack.

## 6.3. Parallel Installation

A. Put the battery module in the cabinet and connect the cable.

- 1) Remove the screws with a screwdriver and disassemble both sides of the handle.
- 2) Put the battery in the cabinet.
- 3) Put back both sides of the handle, lock the screws.
- 4) Repeat the above steps until all batteries are installed.
- 5) Connect the cable between the battery modules.
- 6) The dialing address is pulled out to ensure that the soft switch of the power supply is disconnected.
- 7) Connect the cable to the inverter.

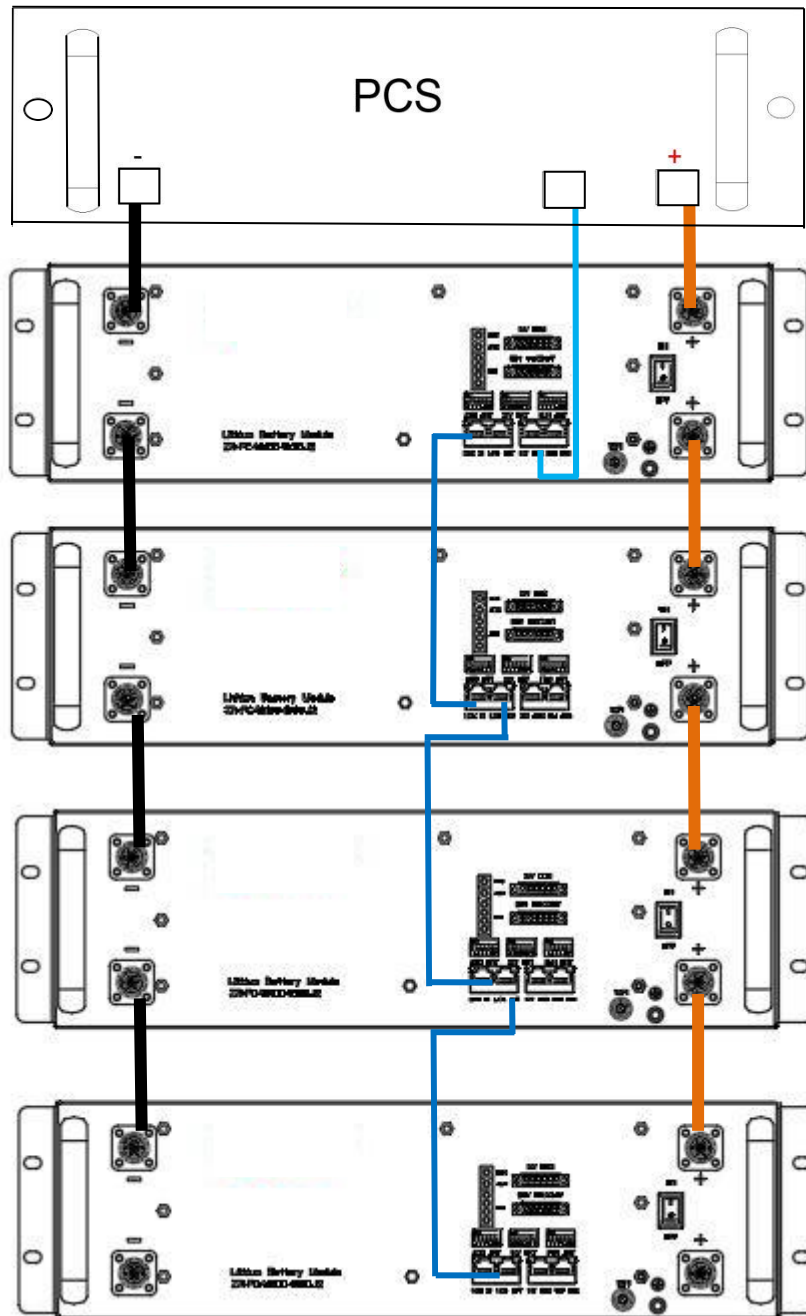

**NOTE:**

DIP Switch setting in parallel mode (Function Dialing Code)

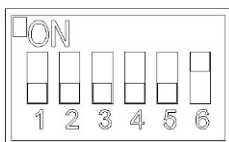

Battery Pack 1

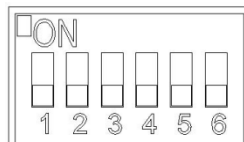

Other Battery Pack

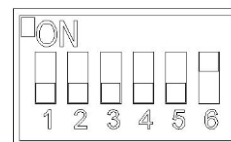

Last Battery Pack

For multi lithium battery systems, the first and last value is fixed at “000001”.

B. Power On

Double check all the power cable and communication cable.

(1) The module with the dialing switch of 1 is the master battery module, and the other modules are the slave battery module (one master battery module can be configured with up to 30 slave battery modules). The inverter must communicate with the battery module with the address of 1

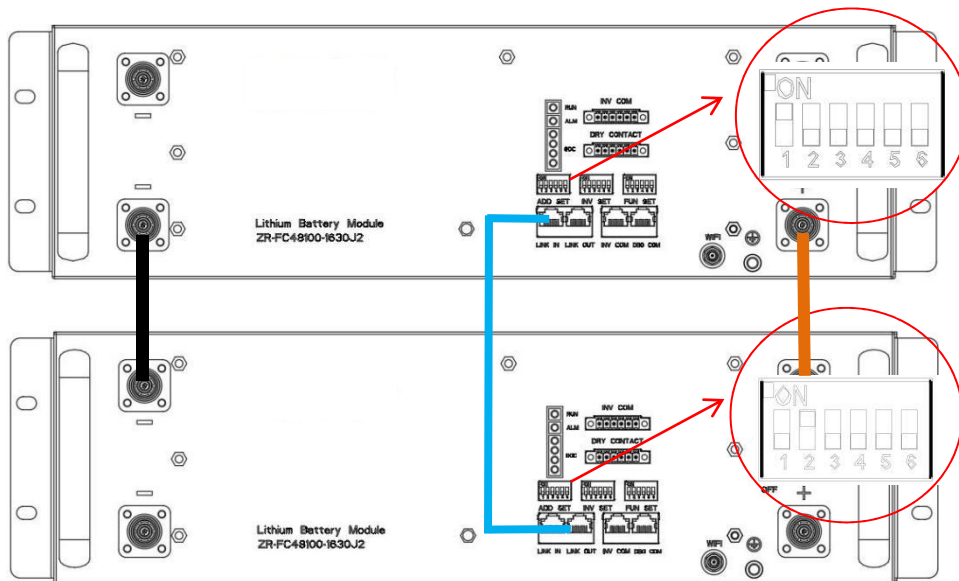



(2) Switch power on

A: Parallel operation

Address dip switch from large to small turn on the battery, and finally turn on battery 1

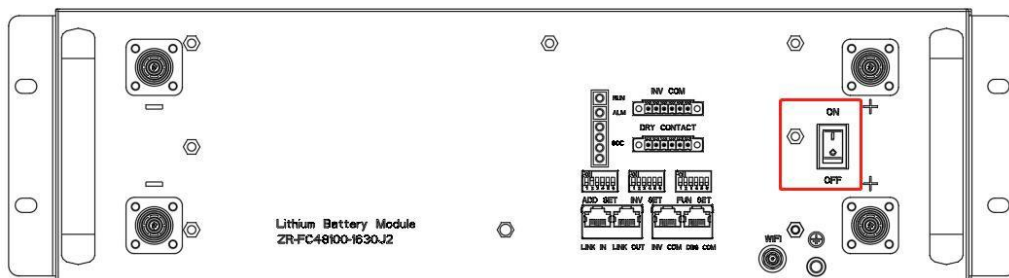
B: One battery



 **NOTE:** After installation, do not forget to register online for full warranty: <http://www.zruipower.com>

**NOTE:**

- To avoid current pulse of the inverter, add on the battery bank. Shall start inverter first or switch on breaker between battery and inverter after all connected batteries turned on.
- Between battery bank and inverter should install breaker to protect system safety.
- All the installation and operation must follow local electric standard.



## 7. Wi-Fi configuration

- 1) Screw the antenna into the antenna connection port firmly before Wi-Fi configuration.

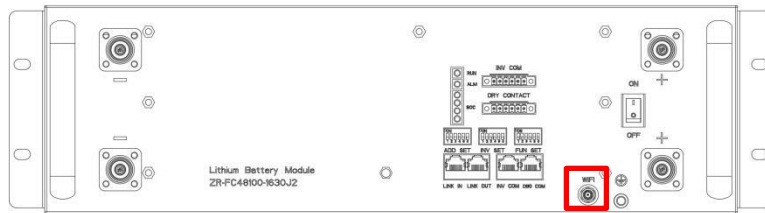
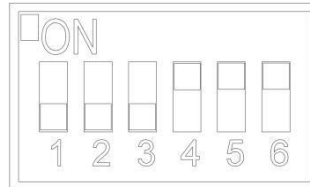

Figure 7.1. WIFI antenna position

- 2) Set the inverter dip switch of the battery to 56 to enable battery WI-FI.



- 3) Download and install ZRGP APP from Google or Apple Store by searching Z-Cloud.

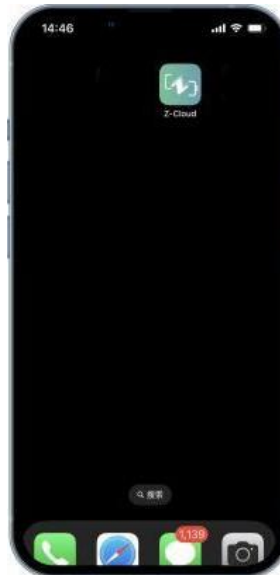

Figure 7.2. Install the APP

- 4) You may acquire the Register Code from your installer for new account registration. If you already had an account, you may use it to login the APP directly otherwise you need to create an account.



Figure 7.3. Start the APP & Create an account & Sign in

- 5) Turn to the page ‘Toolbox’ then click the Network, following by the instruction of network setting for WIFI configuration.

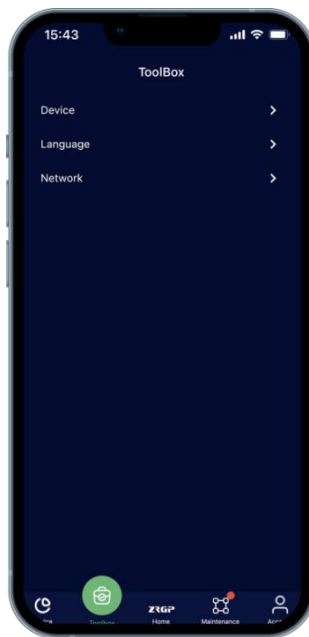

Figure 7.4. Network Setting

- 6) Connect your mobile phone to the WI-FI hotspot from the master controller which SSID is same as controller's serial number (SN) and the password is 12345678.

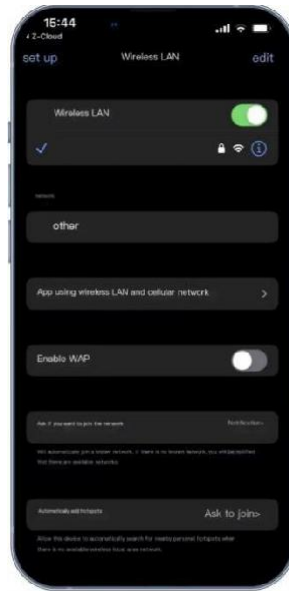

Figure 7.5. Network Setting

- 7) Enter the SSID and password of your private WI-FI for connecting master controller to your private WI-FI.

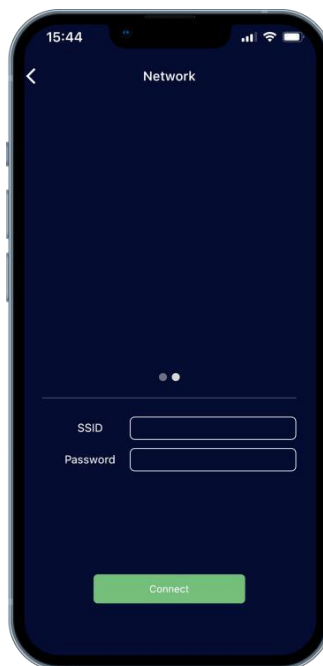

Figure 7.6. Connecting Private Wi-Fi

- 8) Set the inverter dip switch to matching inverter serial number. Please find the detailed comparison table on page 9
- 9) Ask your installer to assign all your products to your account.
- 10) Turn to main page of the APP, create a plant, and set a recognizable name, your email and address for it.

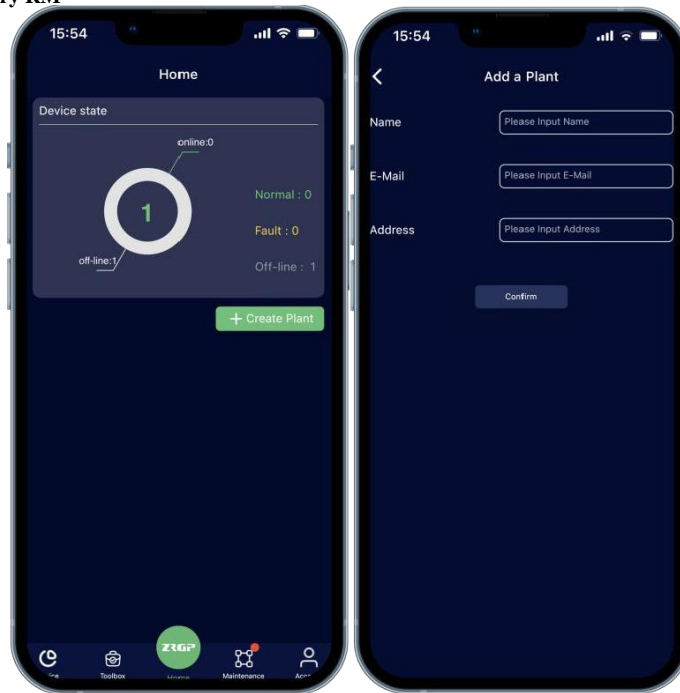

Figure 7.7. Create A New Plant

- 11) Click the confirm button to create your plant and all your products will show up as their SN, select proper products and confirm.

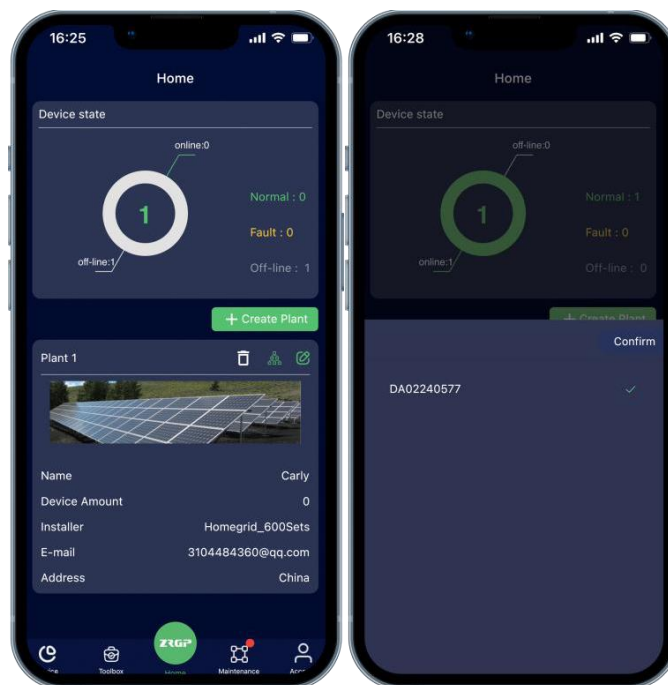

Figure 7.8. Manage Your Plant & Confirm Your Products

- 12) Now you can manage your products in the APP, and you can also manage them in Website, ask your installer for the site URL.

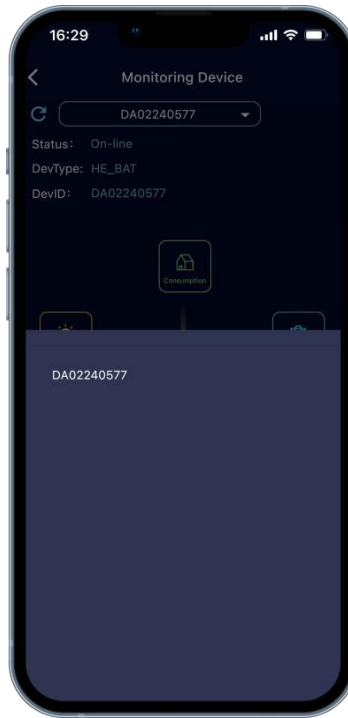

Figure 7.9. Manage Your Products

- 13) After the product is connected to Wi-Fi, the running status, real-time power, daily power consumption and cumulative power of the product can be monitored in real time on the network platform or mobile APP. It can also be used to configure paramete



Figure 7.10. Monitoring Device

## 8. Trouble Shooting Steps

### 8.1. Phenomenon and possible causes of failure

- (1) Unable to turn on the battery.
  - a. Try to charge the battery by the activation charging function of the inverter when power is on.
- (2) No output after power on
  - a. Make sure the address dial code setting is correct, refer to the chapter of address dial code.
  - b. Make sure SOC is not 0% otherwise charge battery please.
- (3) Unable to communicate with inverter.
  - a. Make sure the connection of communication cable and power cable is correct, refer to the chapter of connection of cable and power.
  - b. Make sure the address dial code of the master controller connected to inverter is 1.
  - c. Make sure the inverter dial code of the master controller connected to inverter is correct, refer to the chapter of inverter dial code.
- (4) Unable to be charged by inverter:
  - a. Make sure power cable connection is correct.
  - b. Check whether inverter has faults.
  - c. Check whether grid or PV is available.
  - d. Make sure Time of Use of the inverter setting is correct.
  - c. Make sure charging voltage and charging current setting of the inverter match the parameters of the battery.
  - d. Check the battery low or high temperature protection alarm.
  - e. Check the over current protection alarm.
  - f. Make sure the SOC value is below 96% (default value)
- (5) Unable to discharge while SOC is not zero.
  - a. Make sure the connection of cables is correct and circuit breaker is ON.
  - b. Check whether inverter has faults.
  - c. Make sure the inverter setting is not back up mode.
  - d. Check whether SOC is lower than the shutdown value of the inverter.
  - e. Check the battery low or high temperature protection alarm.
  - f. Check the over current protection alarm.
- (6) Error or Alarm shown on the screen
  - a. Check the battery refer to the definition of the error or warning codes. If cannot solve the

problem, please contact the installer.

- (7) Unable to find the battery on the APP & the cloud
- a. Make sure the antenna is screwed properly.
  - b. Make sure the WIFI configuration is correct.
  - c. Make sure the SSID & PASSWORD of your private WIFI is correct, please enter information case-sensitively without space.
  - d. Make sure the frequency of the WIFI connected to the product is not 5GHz (2.4GHz and 2.4GHz / 5GHz is acceptable).
  - e. Make sure the WIFI signal is strong enough.
  - f. Make sure WIFI is working.
  - g. Make sure installer is distributed your products on user's account.
  - h. Try to restart the WIFI router.

## 8.2.Fault and Troubleshooting

- 1) Cell voltage off-set protection
  - Restart the battery and see if the warning still remaining contact your distributor.
- 2) Low battery voltage Discharge protection
  - Need to be charged.
- 3) Discharge circuit failure
  - Restart the battery and check whether the problem is solved.
- 4) Charge circuit failure
  - Restart the battery and check whether the problem is solved.
- 5) Cell failure
  - Restart the battery and check whether the problem is solved.
- 6) Temperature sensor malfunction
  - Restart the battery and check whether the problem is solved.
- 7) Current sensor malfunction
  - Restart the battery and check whether the problem is solved.
- 8) Short circuit detected
  - Make sure the external connection for both the battery and inverters is proper.
  - Disconnect all external connections and restart the battery.
- 9) Battery voltage sensor malfunction

- Restart the battery and check whether the problem is solved.

10) Communication between controller and battery failure

- Check whether the function dial switch is set according to the user manual.
- Restart the battery.



## 9. Storage, Transportation and Emergency Situations

### 9.1 Storage

Recharge and maintain the battery pack regularly every three months to ensure the battery is in the best condition.

### 9.2 Transportation

Battery packs need to be packed before they can be shipped, during transportation, severe impact, extrusion, direct sunlight, and rain should be protected.

### 9.3 Emergency Situations

#### (1). Leaking Batteries

If the battery pack leaks electrolyte, avoid contact with the leaking liquid or gas. If one is exposed to the leaked substance, immediately perform the actions described below. Inhalation: Evacuate the contaminated area and seek medical attention.

Contact with eyes: Rinse eyes with flowing water for 15 minutes and seek medical attention.

Contact with skin: Wash the affected area thoroughly with soap and water and seek medical attention.

Ingestion: Induce vomiting and seek medical attention.

#### (2). Fire

NO WATER! Only dry powder fire extinguisher can be used; if possible, move the battery pack to a safe area before it catches fire.

#### (3). Wet Batteries

If the battery pack is wet or submerged in water, do not let people access it, and then contact ZRGP or an authorized dealer for technical support.

#### (4). Damaged Batteries

Damaged batteries are dangerous and must be handled with the utmost care. They are not fit for use and may pose a danger to people or property. If the battery pack seems to be damaged, pack it in its original container, and then return it to ZRGP or an authorized dealer.

#### **NOTE:**

- Damaged batteries may leak electrolytes or produce flammable gas.
- In case a damaged battery needs recycling, it shall follow the local recycling regulation (i.e., Regulation (EC) N° 1013/2006 among European Union) to process and use the best available techniques to achieve a relevant recycling efficiency.
- Any further questions, please contact ZRGP: [support@zruipower.com](mailto:support@zruipower.com)



ZHONGRUI GREEN ENERGY TECHNOLOGY (SHENZHEN) CO., LTD.

ADD:RM 706, BLDG. 2, ANBO TECHNOLOGY SQ., BAOLONG 4<sup>TH</sup> RD.,  
LONGGANG DIST., SHENZHEN, CHINA.

Tel: +(0755) 2833 9703

Fax: +86 755-8450 6755

Email: [support@zruipower.com](mailto:support@zruipower.com)

Official website: [www.zruipower.com](http://www.zruipower.com)

Postcode: 518100