



ENGLISH



ZR-FC Series Lithium Battery

User Manual

Table of Contents

1.	Safety Precautions	1
1.1.	General warnings.....	1
1.2.	Charge and discharge warnings.....	2
1.3.	Transportation warnings.....	3
1.4.	Disposal of lithium batteries	3
1.5.	Before Connecting.....	3
1.6.	In Using	4
2.	Introduction.....	5
2.1.	Lithium iron phosphate battery	5
2.2.	ZR-FC Features	5
2.3.	Specifications	6
2.4.	Equipment Interface Instruction.....	7
2.5.	Sleep and Wake up.....	11
2.5.1	Sleep.....	11
2.5.2	Wake up.....	11
2.6.	Forced discharge mode.....	12
2.7.	Automatic parallel.....	12
3.	How to use the ZRGP EmsTools.....	13
3.1.	ZRGP EmsTools connection.....	13
4.	How to match communication with inverter	18
4.1.	Supported brands.....	18
4.2.	Inverter matching list	18
4.3.	Connection with inverter.....	19
5.	Safe handling of lithium batteries Guide.....	20
5.1.	Schematic Diagram of Solution	20
5.2.	Familiar with batteries.....	20
5.3.	Precautions before installation	21
5.4.	Tools.....	21
5.5.	Safety Gear.....	21
6.	Installation	22
6.1.	Package Items.....	22
6.2.	Installation Location.....	23
6.3.	Parallel Installation.....	23
7.	Trouble Shooting Steps.....	26
7.1.	Problem determination based on	26
7.2.	Preliminary determination steps.....	26
7.3.	The battery cannot be charged or discharged.....	26
8.	Storage,Transportationand Emergency Situations.....	27
8.1.	Storage.....	27
8.2.	Transportation	27
8.3.	Emergency Situations.....	27



1. Safety Precautions

It is very important and necessary to read the user manual carefully (in the accessories) before installing or using battery. Failure to do so or to follow any of the instructions or warnings in this document can result in electrical shock, serious injury, or death, or can damage battery, potentially rendering it inoperable.



Observe these instructions and keep them located near the Li-ion Battery for future reference.



For more information about this product, please visit the official website: <http://www.zruipower.com>



Work on a Li-ion Battery should be carried out by qualified personnel only.

1.1. General warnings



While working on the Li-ion Battery wear protective eyeglasses and clothing.



Any uncovered battery material such as electrolyte or powder on the skin or in the eyes must be flushed with plenty of clean water immediately. Then seek medical assistance. Spillages on clothing should be rinsed out with water.



Explosion and fire hazard. Terminals of the Li-ion Battery are always alive; therefore, do not place items or tools on the Li-ion Battery. Avoid short circuits, too deep discharges and too high charge currents. Use insulated tools. Do not wear any metallic items such as watches, bracelets, etc. In case of fire; you must use a type D, foam or CO₂ fire extinguisher.



Do not open or dismantle the battery. Electrolyte is very corrosive. In normal working conditions contact with the electrolyte is impossible. If the battery casing is damaged do not touch the exposed electrolyte or powder because it is corrosive.



Li-ion batteries are heavy. If involved in an accident they can become a projectile! Ensure adequate and secure mounting and always use suitable handling equipment for transportation.



Handle with care because a li-ion battery is sensitive to mechanical shock.



Do not expose cable outside, all the battery terminals must be disconnected



Do not place at a children or pet touchable area.



Do not use cleaning solvents to clean battery.



Do not expose battery to flammable or harsh chemicals or vapors.



Do not paint any part of battery; include any internal or external components.



Do not drop, deform, impact, cut or spearing with a sharp object.



Do not wet the battery and avoid of direct sunlight.



Do not use a damaged battery.



Please contact the supplier within 24 hours if there is something abnormal.



Any foreign object is prohibited to insert into any part of battery.



The warranty claims are excluded for direct or indirect damage due to items above.

1.2. Charge and discharge warnings



If the battery is stored for long time, it is required to charge them every six months, and theSOC should be no less than 90%.



Battery needs to be recharged within 12 hours, after fully discharged.



Do not connect battery with PV solar wiring directly.



Use only with a ZRGP approved BMS.



If charged after the Lithium Battery was discharged below the “Discharge cut-off voltage”, or when the Lithium Battery is damaged or overcharged, the Lithium Battery can release a harmful mixture of gasses such as phosphate.



The temperature range over which the battery can be charged is 0°C to 45°C. Charging the battery at temperatures outside this range may cause severe damage to the battery or reduce battery life expectancy.



The temperature range over which the battery can be discharged is -10°C to 55°C. Discharging the battery at temperatures outside this range may cause severe damage to the battery or reduce battery life expectancy.

1.3. Transportation warnings



The battery must be transported in its original or equivalent package and in an upright position. If the battery is in its package, use soft slings to avoid damage.



Do not stand below a battery when it is hoisted.



Never lift the battery at the terminals or the BMS communication cables, only lift the battery at the handles.

NOTE:

• Batteries are tested according to UN Handbook of Tests and Criteria, part III, sub section 38.3 (ST/SG/AC.10/11/Rev.5).

• For transport the batteries belong to the category UN3480, Class 9, Packaging Group II and have to be transported according to this regulation. This means that for land and sea transport (ADR, RID & IMDG) they have to be packed according to packaging instruction P903 and for air transport (IATA) according to packaging instruction P965. The original packaging complies with these instructions.

1.4. Disposal of lithium batteries



Batteries marked with the recycling symbol must be processed via a recognized recycling agency. By agreement, they may be returned to the manufacturer.



Batteries must not be mixed with domestic or industrial waste.



Do not throw a battery into fire.

1.5. Before Connecting

- ◆ After unpacking, please check product and packing list first, if product is damaged or lack of parts, please contact with the local retailer;
- ◆ Before installation, be sure to cut off the grid power and make sure the battery is in the turned-off mode;
- ◆ Wiring must be correct, do not mistake the positive and negative cables, and ensure no short circuit with the external device;
- ◆ It is prohibited to connect the battery and AC power directly;
- ◆ The embedded BMS in the battery is designed for 48VDC, please DO NOT connect battery in series;
- ◆ Battery system must be well grounded and the resistance must be less than 100mΩ;
- ◆ Make sure the grounding connection set correctly before operation.

◆ Please ensure the electrical parameters of battery system are compatible to related equipment;

◆ Keep the battery away from water and fire.

1.6. In Using

◆ If the battery system needs to be moved or repaired, the power must be cut off and the battery is completely shutdown;

◆ It is prohibited to connect the battery with different type of battery.

◆ It is prohibited to put the batteries working with faulty or incompatible inverter;

◆ It is prohibited to disassemble the battery (QC tab removed or damaged);

◆ In case of fire, only dry powder fire extinguisher can be used, liquid fire extinguishers are prohibited;

◆ Please do not open, repair or disassemble the battery except staffs from ZRGP or authorized by ZRGP. We do not undertake any consequences or related responsibility which because of violation of safety operation or violating of design, production and equipment safety standards.

2. Introduction

ZR-FC series lithium iron phosphate battery is one of new energy storage products developed and produced by ZRGP, it can be used to support reliable power for various types of equipments and systems. ZR-FC series is especially suitable for application scene of high power, limited installation space, and restricted load-bearing and long cycle life.

ZR-FC series has built-in BMS battery management system, which can manage and monitor cells information including voltage, current and temperature. What's more, BMS can help extending cycle life by balancing cells during charging and discharging.

Multiple batteries are allowed to be connected in parallel to expand capacity and power to meet the requirements of longer power supporting duration and higher power consumption..

2.1. Lithium iron phosphate battery

The lithium iron phosphate battery (LiFePO₄ or LFP) is the safest of the mainstream lithium battery types. A single LFP cell has a nominal voltage of 3.2V. A 51.2V LFP battery consists of 16 cells connected in series.

LFP is the chemistry of choice for very demanding applications. Some of its features are:

- ◆ Rugged - It can operate in deficit mode during long periods of time.
- ◆ High round trip efficiency.
- ◆ High energy density - More capacity with less weight and volume.
- ◆ High charge and discharge currents - Fast charge and discharges are possible.
- ◆ Flexible charge voltages.

The lithium iron phosphate battery is therefore the chemistry of choice for a range of very demanding applications.

2.2. ZR-FC Features

- ◆ The whole module is non-toxic, non-polluting and environmentally friendly;
- ◆ Cathode material is made from LiFePO₄ with safety performance and long cycle life;
- ◆ Battery management system (BMS) has protection functions including over-discharge, over-charge, and over-current and high/low temperature;
- ◆ The system can automatically manage charge and discharge state and balance current and voltage of each cell;
- ◆ Flexible configuration, multiple battery modules can be in parallel for expanding capacity and power, up to 63 batteries in parallel.;
- ◆ Adopted self-cooling mode rapidly reduced system entire noise;
- ◆ The module has less self-discharge, up to 6 months without charging it on shelf, no memory effect, excellent performance of shallow charge and discharge;
- ◆ Working temperature range is from -10 to 55 °C , (Charging 0~45 °C ; discharging -10~55 °C)with excellent discharge performance and cycle life;
- ◆ Small size and light weight, standard of 19-inch embedded designed module is easy for installation and maintenance;

2.3. Specifications

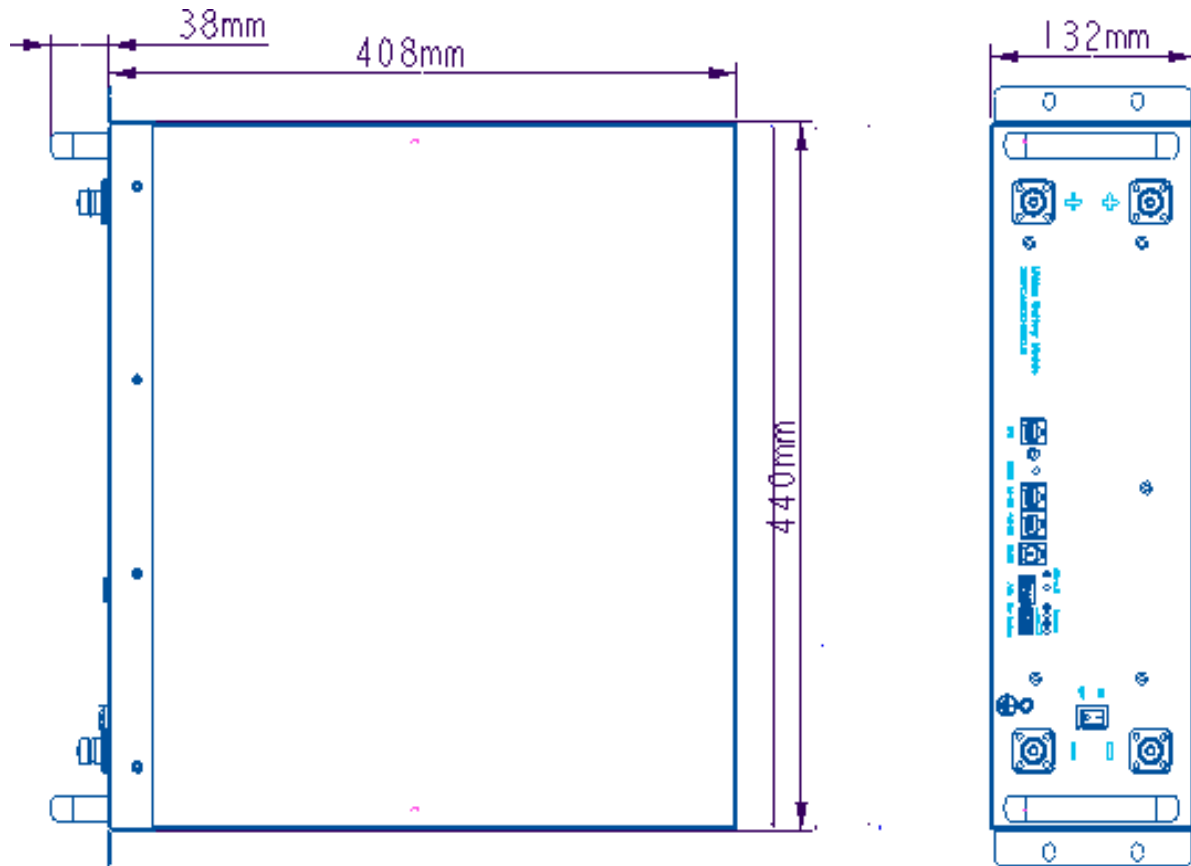

Figure 2.1. Outline dimensional drawing

NO.	Item	ZR-FC4850		ZR-FC48100		ZR-FC-24200
1	Battery Model	50Ah/3.2V		100Ah/3.2V		200Ah/3.2V
2	Compound Mode	1P16S	1P15S	1P16S	1P15S	2P8S
3	Rated Capacity	50Ah		100Ah		200Ah
4	Rated Energy	2560Wh	2400Wh	5120Wh	4800Wh	5120W
5	Initial Resistance	<50MΩ				
6	Nominal Voltage	51.2V	48V	51.2V	48V	25.6V
7	Charge Cut-off Voltage	57V	53.4V	57V	53.4V	28.5V
8	Discharge Cut-off Voltage	48V	45V	48V	45V	24V
9	Rated Charging Current	10A		20A		20A
10	Maximum Charging Current	≤50A		≤100A		≤100A
11	Rated Discharge Current	25A		50A		50A
12	Maximum Discharge Current	≤50A		≤100A		≤100A
13	Charging Temperature	-0~+45℃				
	DisChargeTemperature	-10~+55℃				
14	Open-circuit voltage	44.8~57.6V				23.8~28.8
15	Shell Type	Painted metal				
16	Weight	33±1Kg	31.7±1Kg	45±1Kg	43±1Kg	45±1Kg
17	Size	408(L)*440(W)*132(H)mm				

2.4. Equipment Interface Instruction

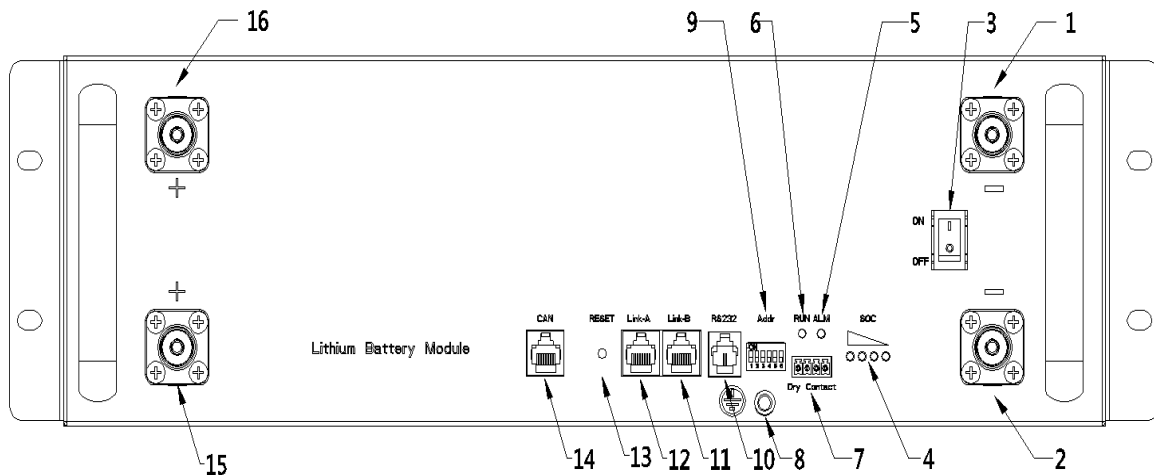

Figure 2.2. Interface definition

No.	Instructions	NO.	Instructions
1	Battery cathode 1 (same as the port 2)	9	Address dial switch
2	Battery cathode 2 (same as the port 1)	10	RS232 communication port
3	Power switch	11	Multi-device parallel connection 1
4	SOC indicator	12	Multi-device parallel connection 2
5	Alarm indicator	13	Reset button
6	Run indicator	14	CAN/RS485 communication port
7	Dry contact	15	Battery anode 1 (same as the port 16)
8	GND	16	Battery anode 2 (same as the port 15)

Power switch

Power switch: to turn ON/OFF the whole battery. When it's off, BMS standby, no power output.

Dry contact

Dry contact: provided 2 ways output dry contact signal.

Address dial switch

ADD Switch: 6 ADD switches, "0" and "1", refer to picture right. The settings will be active only after restart the battery.



When the battery communicates with the inverter, the address of the battery pack must be set to 1, and the address of the parallel slave should be greater than 1.

When the battery Pack is connected in parallel, cascading communication is required. Hardware address configuration is required for both the master PACK and the slave PACK, and the hardware address can be set by the dial switch on the board. The definition of the switch refers to the table below.

Address Coding	Dial Code Switch Position						Definition
	#1	#2	#3	#4	#5	#6	
1	ON	OFF	OFF	OFF	OFF	OFF	Set the master Pack, and the inverter communicates with the battery at that address
2	OFF	ON	OFF	OFF	OFF	OFF	Set to the slave Pack1
3	ON	ON	OFF	OFF	OFF	OFF	Set to the slave Pack 2
4	OFF	OFF	ON	OFF	OFF	OFF	Set to the slave Pack 3
5	ON	OFF	ON	OFF	OFF	OFF	Set to the slave Pack 4
6	OFF	ON	ON	OFF	OFF	OFF	Set to the slave Pack 5
7	ON	ON	ON	OFF	OFF	OFF	Set to the slave Pack 6
8	OFF	OFF	OFF	ON	OFF	OFF	Set to the slave Pack 7
9	ON	OFF	OFF	ON	OFF	OFF	Set to the slave Pack 8
10	OFF	ON	OFF	ON	OFF	OFF	Set to the slave Pack 9
11	ON	ON	OFF	ON	OFF	OFF	Set to the slave Pack10
12	OFF	OFF	ON	ON	OFF	OFF	Set to the slave Pack 11
13	ON	OFF	ON	ON	OFF	OFF	Set to the slave Pack 12
14	OFF	ON	ON	ON	OFF	OFF	Set to the slave Pack13
15	ON	ON	ON	ON	OFF	OFF	Set to the slave Pack 14
16	OFF	OFF	OFF	OFF	ON	OFF	Set to the slave Pack 15
⋮	⋮	⋮	⋮	⋮	⋮	⋮	⋮
62	OFF	ON	ON	ON	ON	ON	Set to the slave Pack 61
63	ON	ON	ON	ON	ON	ON	Set to the slave Pack 62

RS232 communication port

RS232 communication port: (RJ11 port) comply with RS232 protocol (baud rate: 9600), for manufacturers or professional engineers debugging or service.

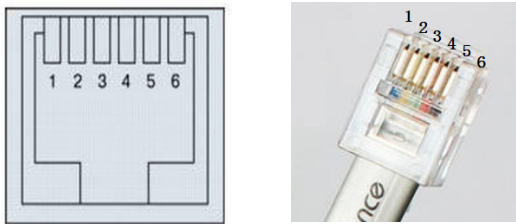
Port definitions	RJ11 Pin	Function
	1	NC
	2	RS232-GND
	3	RS232-TX
	4	RS232-RX
	5	RS232-GND
	6	NC

Multi-device parallel connection 1 and Multi-device parallel connection 2

Multi-device parallel connection: The same RJ45 port, two RJ45 parallel. Comply with RS485 protocol (baud rate: 9600), used for parallel communication between batteries.

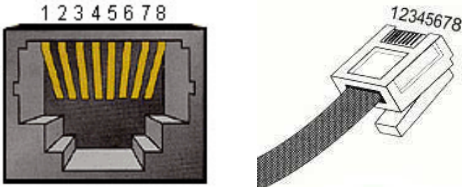
Port definitions	RJ45 Pin	Function
	1	RS485-B
	2	RS485-A
	3	RS485-GND
	4	NC(No connect)
	5	NC(No connect)
	6	RS485-GND
	7	RS485-A
	8	RS485-B

Reset button

- ◆ When Battery is in sleep mode, press the key for 3S and release it, the Battery will be activated, and the LED indicators will light up from left to right, and then showing the SOC of the battery.
- ◆ When Battery is in the active state, press the key for 3S and release it, the Battery will go into sleep mode, and the LED indicators will light up from right to left and then all the indicators will be off.
- ◆ When Battery is in the active state, press the button for 6S and then release, the battery parameters are restored to factory settings, and all LED lights are on for 1.5 seconds.

NOTE:

● If there are other batteries in the output state in parallel application scenario, the current battery cannot be set to sleep through the reset button at this time, because it will be charged and awakened by other batteries with normal output.

CAN/RS485 communication port

CAN/RS485 communication port: (RJ45 port) follow CAN protocol and RS485 protocol, for output batteries information, the battery uses this interface to communicate with external inverters, PCS and other devices.

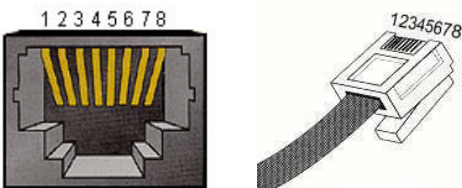
Port definitions	RJ45 Pin	Function
	1	RS485-B
	2	RS485-A
	3	NC(No connect)
	4	NC(No connect)
	5	RS485-GND\CAN-GND
	6	NC(No connect)
	7	CANH
	8	CANL

Battery anode and Battery cathode

Battery anode and Battery cathode: there are two pair of terminals with same function, one connect to equipment, the other one paralleling to other battery module for capacity expanding. For each single module, each terminal can achieve charging and discharging function. For power cables uses water-proofed connectors. It must keep pressing this LockButton while pulling out the power plug.

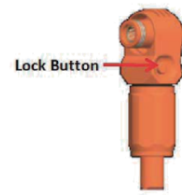

SOC indicator, Alarm indicator and Run indicator

- ◆SOC indicator: 4 green LEDs to show the battery’s current capacity.
- ◆Alarm indicator: red LED flashing to show the battery has alarm, and always-on to show the battery is under protection.
- ◆Run indicator: green LED always-on to show the battery running status, flashing when charging, and lighting when discharging;

Table 1 LED working state indication

State	Normal Warning protect	Run	ALM	LED capacity indicator				Indicate
		●	●	●	●	●	●	
Shutdown	Powerdown	OFF	OFF	OFF	OFF	OFF	OFF	All off
Standby	Normal	Flash 1*	OFF	According to capacity indication				standby
	Alarm	Flash 1*	Flash 3*					Low Voltage
Charging	Normal	ON	OFF	According to capacity indication (Maximum indicator LED flash 2)				Overcharge alarm ALM light does not flicker
	Warning	ON	Flash 3*					
	Protect	ON	OFF	ON	ON	ON	ON	Stop charging
	Temperature, overcurrent, failure protection	OFF	ON	OFF	OFF	OFF	OFF	Stop charging
Discharging	Normal	Flash 3*	OFF	According to capacity indication				\
	Warning	Flash 3*	Flash 3*					
	Protect	ON	OFF	ON	ON	ON	ON	Stop Discharging
	Temperature, overcurrent, Short, failure protection	OFF	ON	OFF	OFF	OFF	OFF	Stop Discharging
Failure	Failure	OFF	ON	OFF	OFF	OFF	OFF	Stop charging and Discharging
Parallel	Address >1 and not connected	Flash 3*	\	\	\	\	\	The slave waits for parallel state

*See definition for Flash 1/2/3 in the following page.

Table 2 Capacity Indication

State		Charging				Discharging			
Capacity indication light		L4 ●	L3 ●	L2 ●	L1 ●	L4 ●	L3 ●	L2 ●	L1 ●
Capacity (%)	0~25%	OFF	OFF	OFF	Flash 2	OFF	OFF	OFF	ON
	25~50%	OFF	OFF	Flash 2	ON	OFF	OFF	ON	ON
	50~75%	OFF	Flash 2	ON	ON	OFF	ON	ON	ON
	75~100%	Flash 2	ON	ON	ON	ON	ON	ON	ON
RUN indication light ●		ON				Flash 3			

Table 3 LED flashing instructions

Flashing way	ON	OFF
Flash 1	0.25S	3.75S
Flash 2	0.5S	0.5S
Flash 3	0.5S	1.5S

2.5. Sleep and Wake up

2.5.1 Sleep

When any of the following conditions is met, the battery enters the low-power mode:

- 1) Under voltage protection is not released within 30 seconds.
- 2) Press the reset button for 3 seconds and then release the button.

NOTE:

● If there are other batteries in the output state in parallel application scenario, the current battery cannot be set to sleep through the reset button at this time, because it will be charged and awakened by other batteries with normal output.

- 3) The lowest cell voltage is lower than the sleep voltage, and the duration reaches the sleep delay time (while meeting the requirements of no communication, no protection, no equilibrium, and no current).
- 4) Standby mode lasts for more than 24 hours (no communication, no charge and discharge, no mains power, minimum cell is less than 3.2V).
- 5) Forced shutdown from the ZRGP EmsTools.

Before entering sleep, make sure no charger is connected, otherwise it will not be able to enter low-power mode.

2.5.2 Wake up

When the system is in the low-power mode and any of the following conditions is satisfied, the system will exit the low-power mode and enter the normal operation mode:

- 1) Connect the charger, and the output voltage of the charger must be greater than 48V.
- 2) Press the reset button for 3 seconds and release the button.
- 3) Connect the communication line and open the ZRGF EmsTools (if enters sleep mode due to over-release protection, and this method cannot wake up the battery).
- 4) Use the power software switch.

NOTE:

● After battery over-discharge protection, it enters the low-power mode, wakes up at a regular time every 4 hours, and starts open switch to charging or discharging. If it can be charged, it will exit the sleep mode and enter the normal charging state. If the auto wake up fails to charge for 10 consecutive times, it will no longer auto wake up. When the system is defined as the end of charging, and the recovery voltage is still not reached after 2 days /48h standby time (standby time set value), it is forced to resume charging until the end of recharging.

2.6. Forced discharge mode

When the battery is in the sleep mode by undervoltage protect and the lowest cell is greater than 2.0V, first close the power switch, and then wait for 2S before turning on the power switch, and the battery enters the forced discharge mode for 5 minutes. In the forced discharge mode, if there is a charge, the battery will exit the forced discharge mode and switch to the normal mode. If the discharge current exceeds 20A or there is no charge current within 5 minutes, the battery will re-enter the sleep mode.

2.7. Automatic parallel

With automatic parallel function; when the slave battery (address > 1) is powered on, the charge and discharge switch is in disconnect state. When the voltage difference between the slave battery and master battery is less than the condition of "the minimum voltage difference between the slave and the master", the master sends the command to the slave. After the slave receives the command from the master, the charge and discharge switch will be connected and the slave is integrated into the master system to complete the parallel operation.

3. How to use the ZRGP EmsTools

3.1. ZRGP EmsTools connection

- 1) Connect the RS232 interface of the battery to the computer using the RS232 communication line (this accessory is an optional accessory, need to be purchased separately from the manufacturer).
- 2) Unzip the package file of the ZRGP EmsTools in the same file directory, pay attention to the directory do not store other files.



Figure 3.1. Unzip of ZRGP EmsTools

- 3) Open the ZRGP Emstools icon, enter the Protocol selection interface, select the EMS Pack Protocol version and enter the password (please contact the manufacturer for the password) to log in the software.

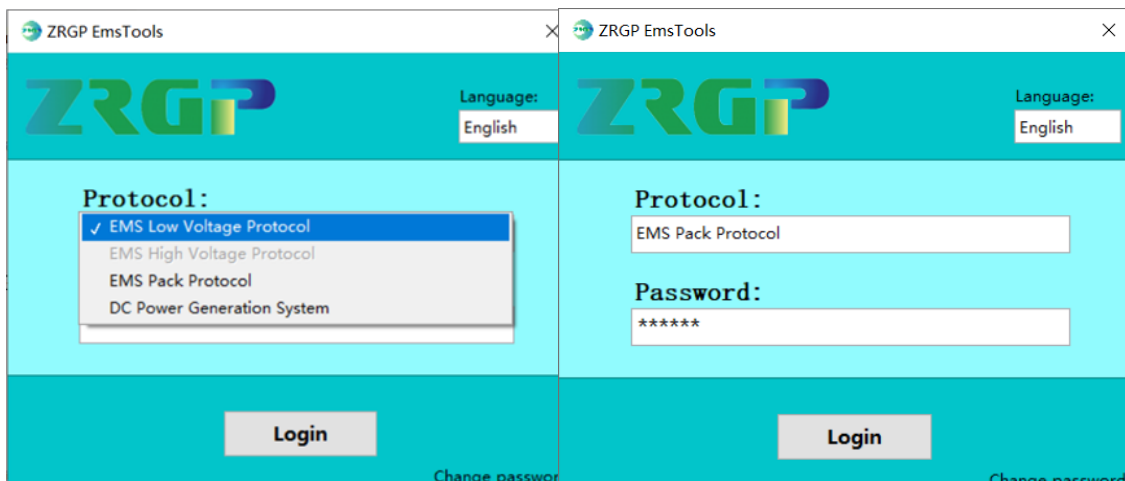

Figure 3.2. Protocol selection interface

Figure 3.3. Enter the password

- 4) Users can set different languages according to their own needs. We support four languages, which are Simplified Chinese, English, Japanese and Spanish.

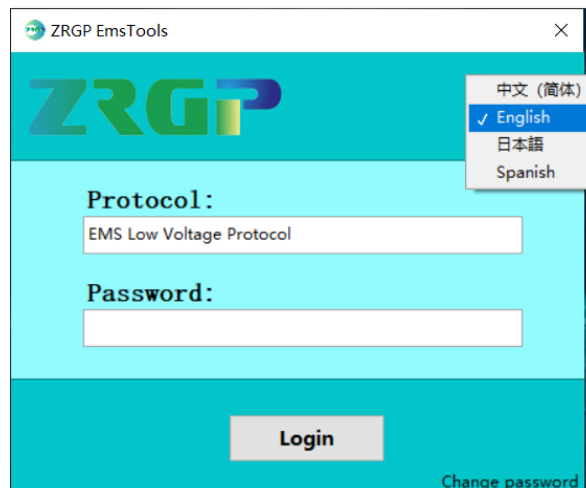

Figure 3.4. ZRGP Emstools language selection

- Select the serial port number in the EMS low-voltage version of the ZRGP Emstools, and the baud rate is 9600 by default. Click "Open COM" and "Monitor ON" button.

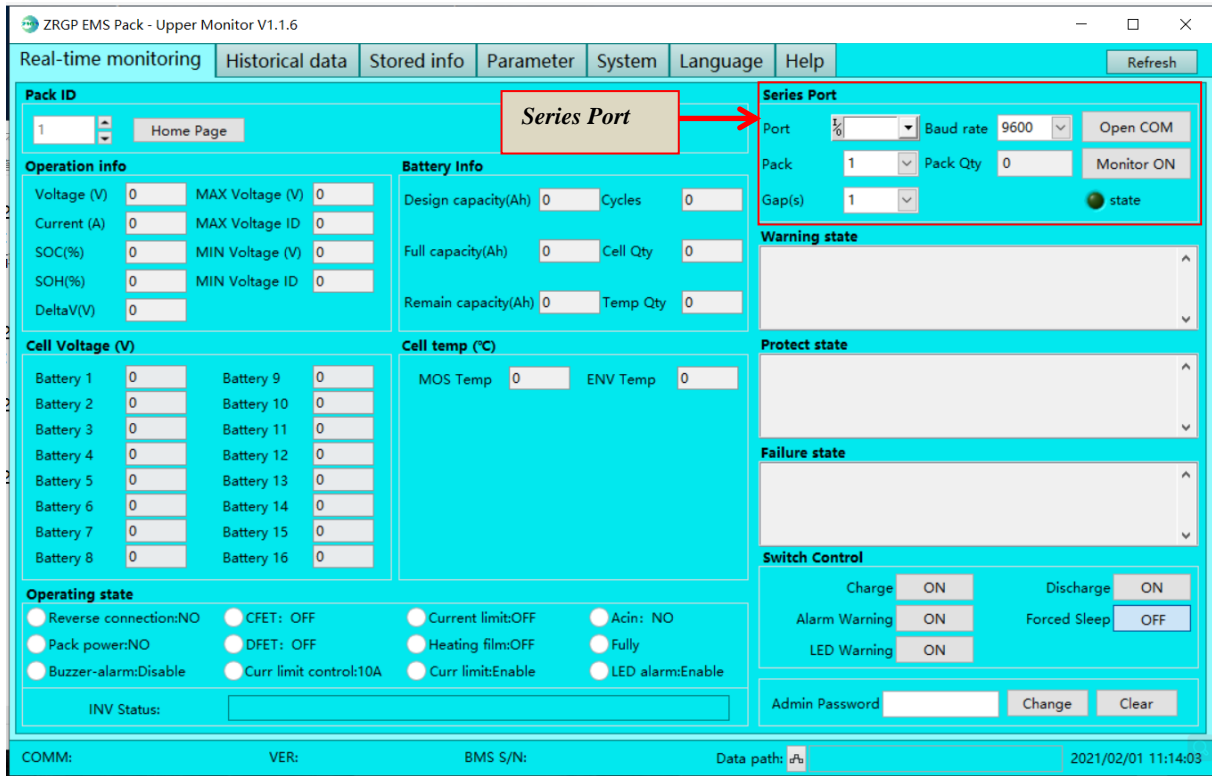

Figure 3.5. ZRGP Emstools serial port settings

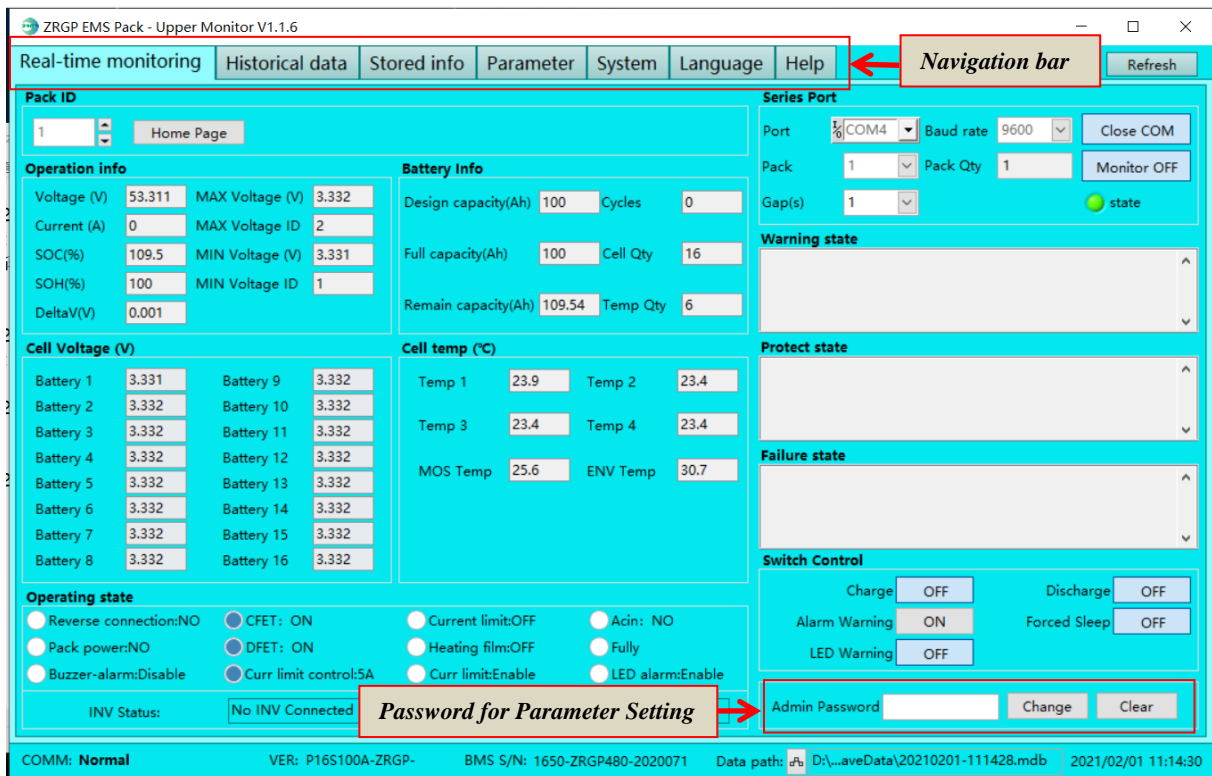

Figure 3.6. ZRGP Emstools data acquisition

- The corresponding functions can be selected through the navigation bar of the ZRGP EMS Pack.

7) Historical data recording

ZRGP Emstools supports real-time data recording function, which can record the parameters and state information of the battery when it is running.

By clicking the Historical data menu to switch, all the historical data which collected by ZRGP Emstools can be read at any time, those historical also can be export to computer and save into Excel format files.

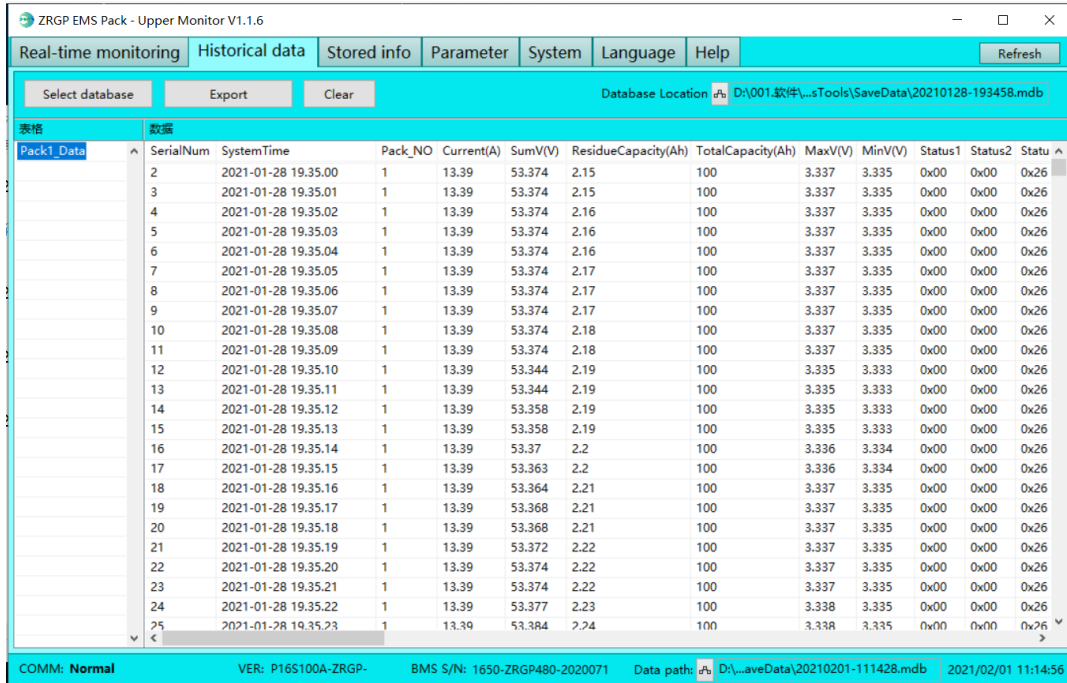

Figure 3.7. ZRGP Emstools historical data recording

8) Log recording

The BMS inside the battery pack uses FLASH chip to record the battery operation data, these data mainly include some parameters such as alarm, protection, fault, state switch, etc., and after-sales personnel can evaluate and analyze the running state of the product according to this log information, battery can support log recording for more than 10 years at most.

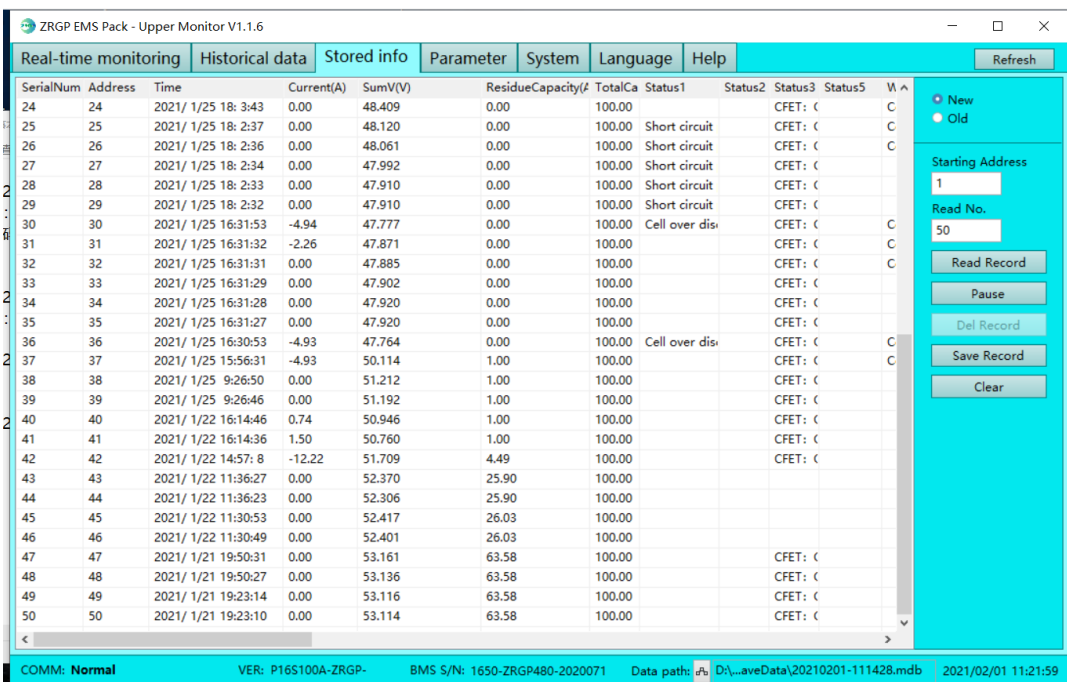

Figure 3.8. ZRGP Emstools Log recording

9) Parameter Setting

ZRGP EMS Pack supports the setting and modification of battery alarm, protection and other parameters. The user needs to enter the password in the lower right corner of the Real-time Monitoring page (the password needs to be obtained from the manufacturer) to modify and set these parameters, refer to Figures 3.6 and Figures 3.9.



Figure 3.9. ZRGP Emstools Parameters Setting

10) Language Setting

In addition to setting the language on the login interface, users can also set it in the “language” option card in the navigation bar, as shown below:

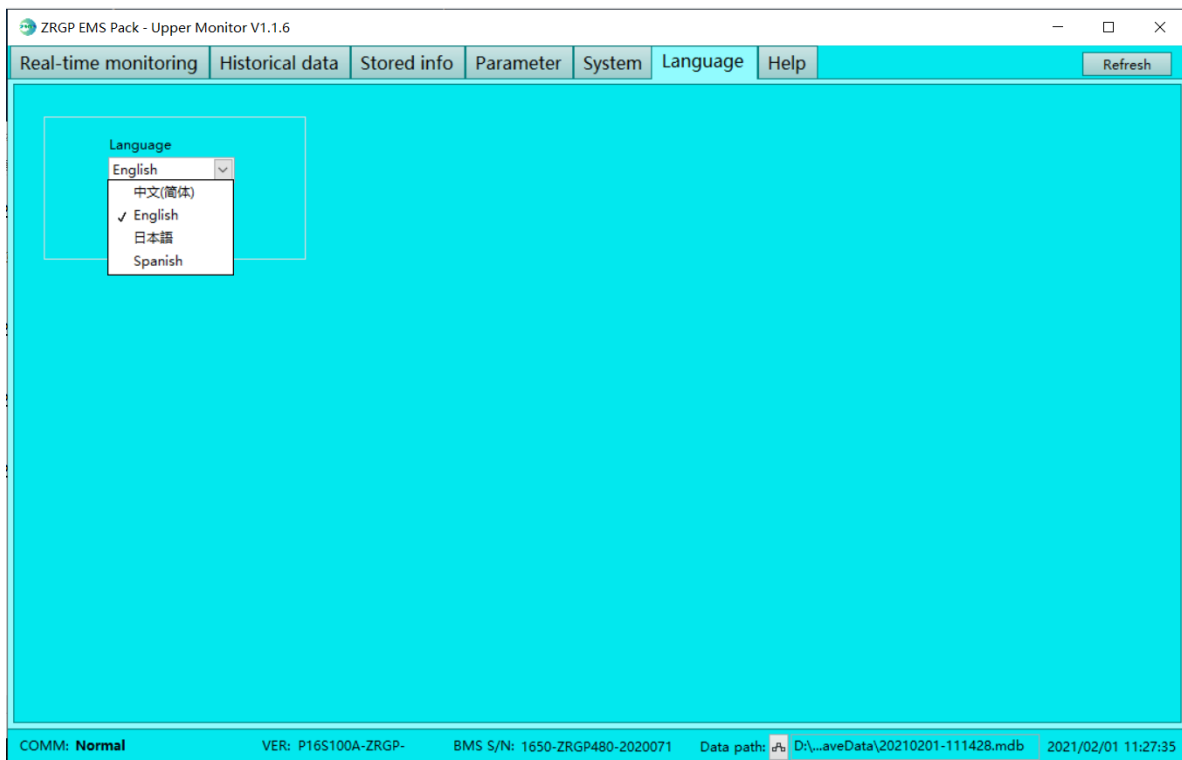

Figure 3.10. ZRGP Emstools Language Setting

11) Help

The user can learn about the ZRGP EMS Pack software and open the help file at the “Help” option card in the navigation bar.



Figure 3.11. ZRGP Emstools Help Function

4. How to match communication with inverter

4.1. Supported brands

At present, the energy storage products of our company have completed matching tests with some series inverters of the following brands, and we will continue matching tests with inverters of other companies. Please check our official website for the latest list of supporting brands. <http://www.zruipower.com>.



4.2. Inverter matching list

The list tab only lists the inverter manufacturers one of the same series products, general inverter manufacturers in the same series of other products, the communication protocol are the same, so our battery can be communicated with the other products of same series inverter, if encounter a series of products can't communication, please contact us.

The following inverter matching list may not be up to date. The list may change according to the software version upgrade, and the reference manual may does not change immediately according to the software version upgrade. Therefore, if the user wants to get the latest inverter matching support, please browse our the official website to check the relevant documents, <http://www.zruipower.com>.

The inverter manufacturer may upgrade its software version, which may cause problems in the communication between our battery and the inverter. Therefore, before communicating with the inverter, please confirm whether the software version of the inverter is consistent with the list. If not, please contact us.

Inverter			ZR-FC Firmware version	Communication mode
Brand	Type	Protocol Version		
Growatt	SPF 12KT HVM	1.22	V439	RS485
Studer	Xtender-XTH-8000-48	V1.0.3		Xcom-CAN
Sofar	HYD5000-ES	V6.0		CAN
Solis	RHI-5K-48ES	V1.2		CAN
Goodwe	GW5048-EM	V1.5		CAN
Victron	MultiPlus-II	V6.0		CAN
SMA	S16.0H-12	V2.0		CAN
Sermatec	SMT-5K-TL-UN	V1.2		CAN
Schneider	ConextTM Gateway	V2.0		RS485
PYLON	SUNSYNK-5K-SG01LP1	V1.2		CAN
Li_PLUS	ZRStandard	V1.2		CAN

4.3. Connection with inverter

This section will introduce how to hardware connect ZR-FC series products with 8.2 section “Inverter Matching List”. Inverters manufacturers may upgrade their products, resulting in hardware communication interface changes. If communication is not possible in the application according to the following wiring method, please contact with us.

The CAN/RS485 communication port of ZR-FC is connected with the communication interface of inverter.

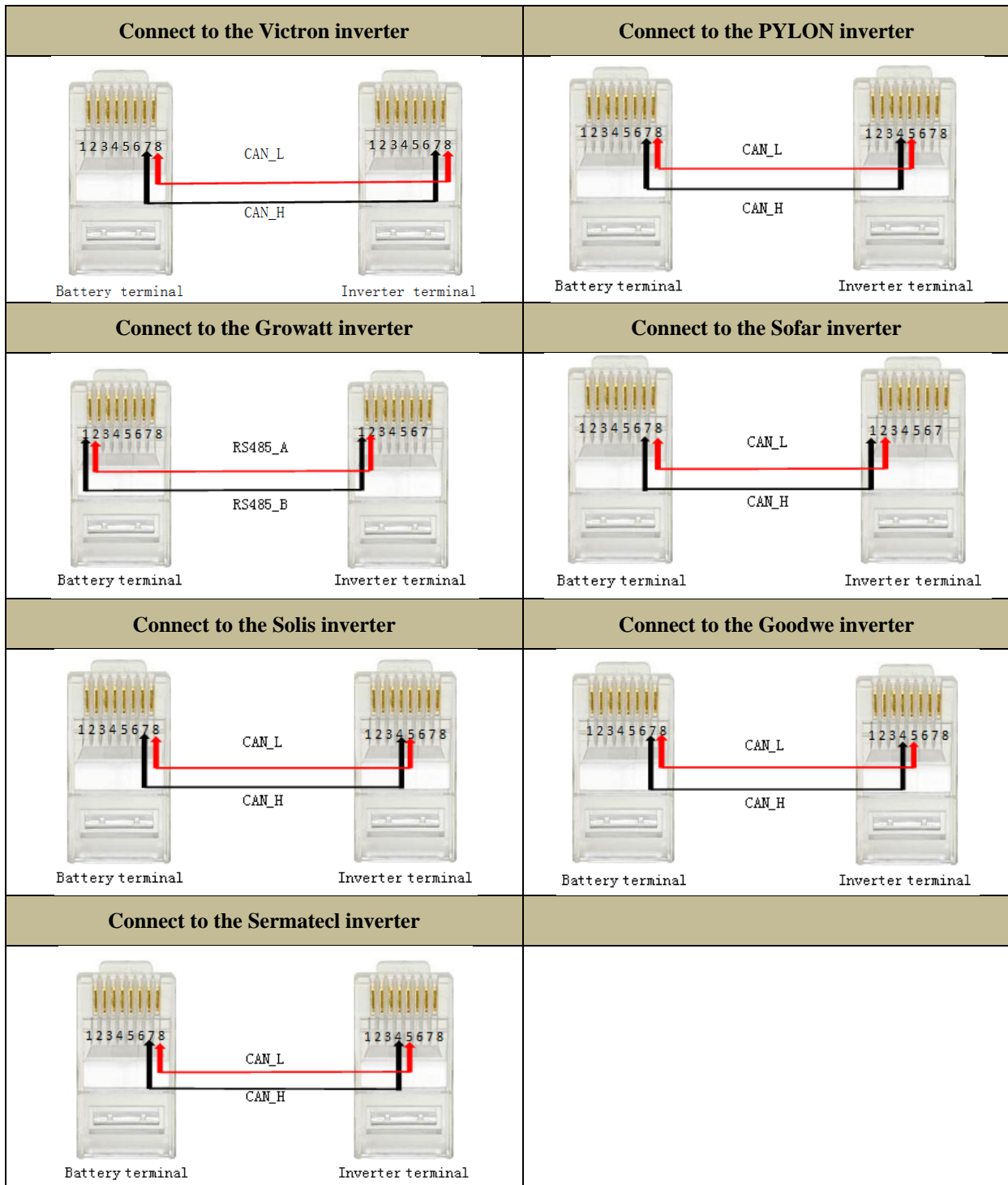

NOTE:

●The above CAN and RS485 communication connections are not connected the ground wire, in the application of relatively large interference, it is recommended to connect the ground wire, the ground wire connection method is a single-ended shielding line.

5. Safe handling of lithium batteries Guide

5.1. Schematic Diagram of Solution

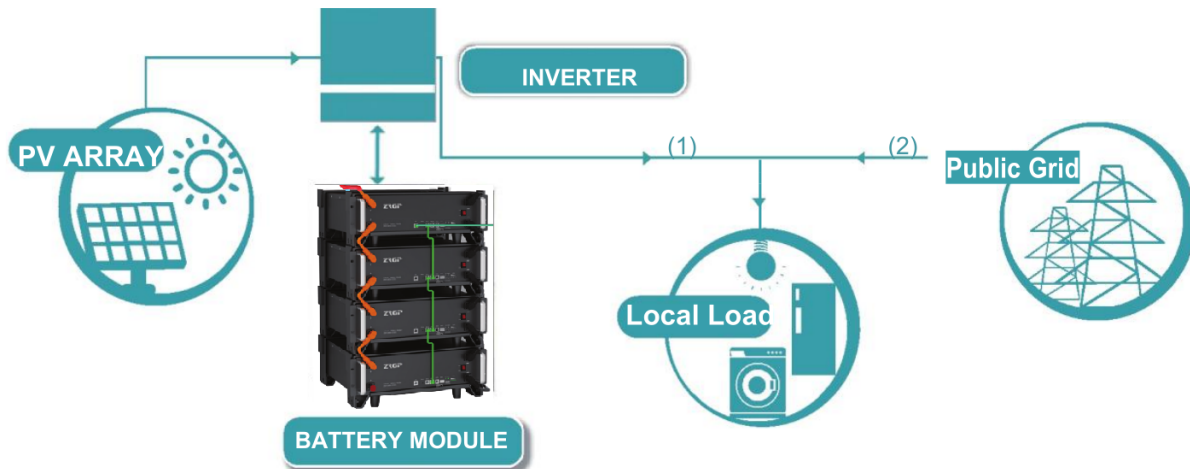

Figure 5.1. Schematic diagram of solution

5.2. Familiar with batteries

Be careful when opening the battery package. The battery is heavy. Don't lift it with a pole. There are two handles on both sides of the battery. The weight of the battery can be found in the chapter "Specifications".

Familiar with batteries. The battery poles are located on both sides of the battery. The battery polarity is displayed on both sides of the battery. The positive pole is represented by "+" and the negative pole by "-".



Figure 5.2. Side view of ZR-FC Battery



Figure 5.3. Front view of ZR-FC Battery

5.3. Precautions before installation

Before installation, be sure to read the contents in Chapter 1 Safety Precautions, which is related to the operation Safety of installation personnel, please pay attention to.

5.4. Tools

The following tools are required to install the battery pack:



Wire cutter Crimping Modular Plier Screw Driver

NOTE:

● Use properly insulated tools to prevent accidental electric shock or short circuits. If insulated tools are not available, cover the entire exposed metal surfaces of the available tools, except their tips, with electrical tape.

5.5. Safety Gear

It is recommended to wear the following safety gear when dealing with the battery pack:



Insulated gloves Safety goggles Safety shoes

6. Installation

6.1. Package Items

Unpacking and check the Packing List:

1) Connector

Each battery will be equipped with a positive connector and a negative connector, the two connectors are not connected to the cable, and the user can be wired according to the actual application needs.



Positive connector

Negative connector

2) Connector For battery module package

Two long power cables (current capacity 120A) and one communication cable for each battery package:

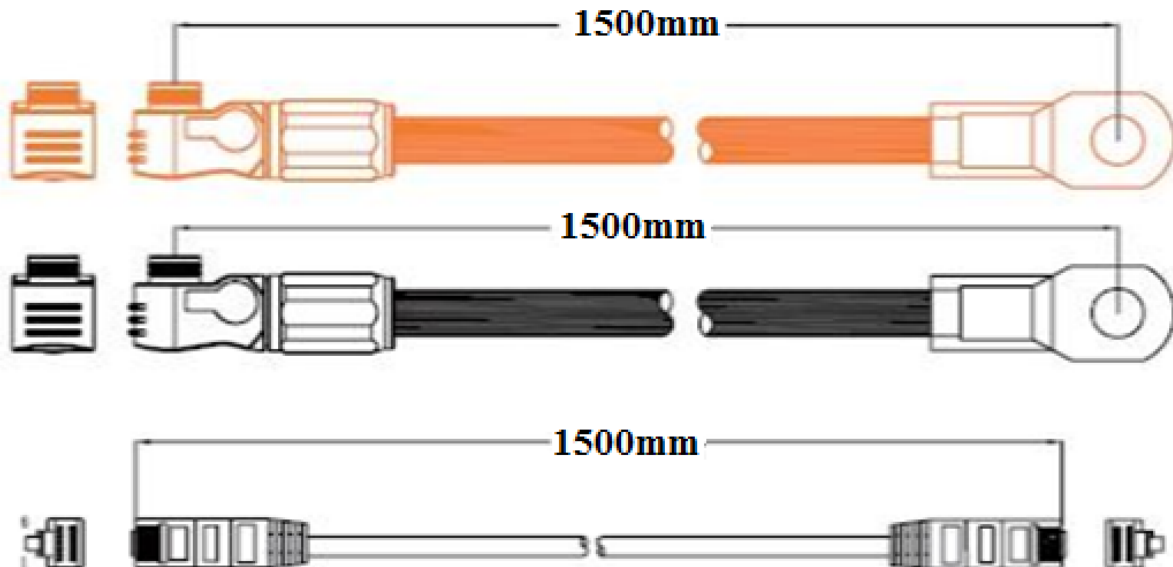

3) Grounding cable

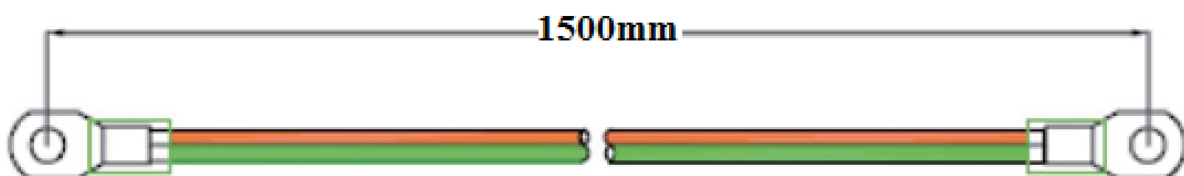

Grounding cables use 10AWG yellow-green cables.

ZR-FC modules' grounding is based on metal directly touch between the module's surface and rack's surface. So it doesn't need grounding cables at all. If uses normal rack, it can remove the paint at the corresponding place, or install a grounding cable to the grounding point of the modules.



6.2. Installation Location

Make sure that the installation location meets the following conditions:

- ◆ The area is completely water proof.
- ◆ The floor is flat and level.
- ◆ There are no flammable or explosive materials.
- ◆ The ambient temperature is within the range from 0°C to 50°C.
- ◆ The temperature and humidity is maintained at a constant level.
- ◆ There is minimal dust and dirt in the area.
- ◆ The distance from heat source is more. than 2 meters
- ◆ The distance from air outlet. of inverter is more than 0.5 meters.
- ◆ Do not install outside directly
- ◆ Do not cover or wrap the battery case or cabinet.
- ◆ Do not place at a children or pet touchable area.
- ◆ The installation area shall avoid of direct sunlight.
- ◆ There is no mandatory ventilation requirements for battery module, but please avoid of installation in confined area. The aeration shall avoid of high salinity, humidity or temperature.
- ◆ A DC isolator is recommended to be add on the power circuit between inverter and battery, recommended rating at 120Amps per set of external power cable.



CAUTION

If the ambient temperature is outside the operating range, the battery pack stops operating to protect, itself. The optimal temperature range for the battery pack to operate is 0°C to 50°C. Frequent exposure, to harsh temperatures may deteriorate the performance and life of the battery pack.

6.3. Parallel Installation

A. Put the battery module in the cabinet and connect the cable

- (1) Put the battery in the cabinet;
- (2) Fix 4 PC screws;
- (3) Connect the cable between the battery modules;
- (4) The dialing address is pulled out to ensure that the soft switch of the power supply is disconnected;
- (5) Connect the cable to the inverter;



B. Power On

Double check all the power cable and communication cable.

(1) Switch power on

Switch on all the battery modules:



(2) The module with the dialing switch of 1 is the master battery module, and the other modules are the slave battery module (one master battery module can be configured with up to 62 slave battery modules). The inverter must communicate with the battery module with the address of 1

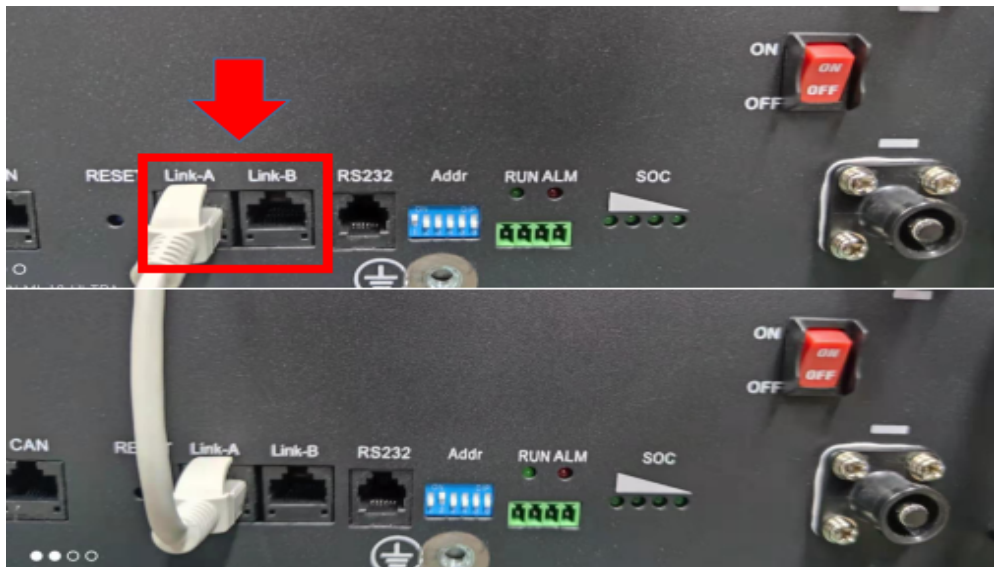

(3) Press the red button of master battery to power on, all the battery LED light will be on one by one from the Master battery:

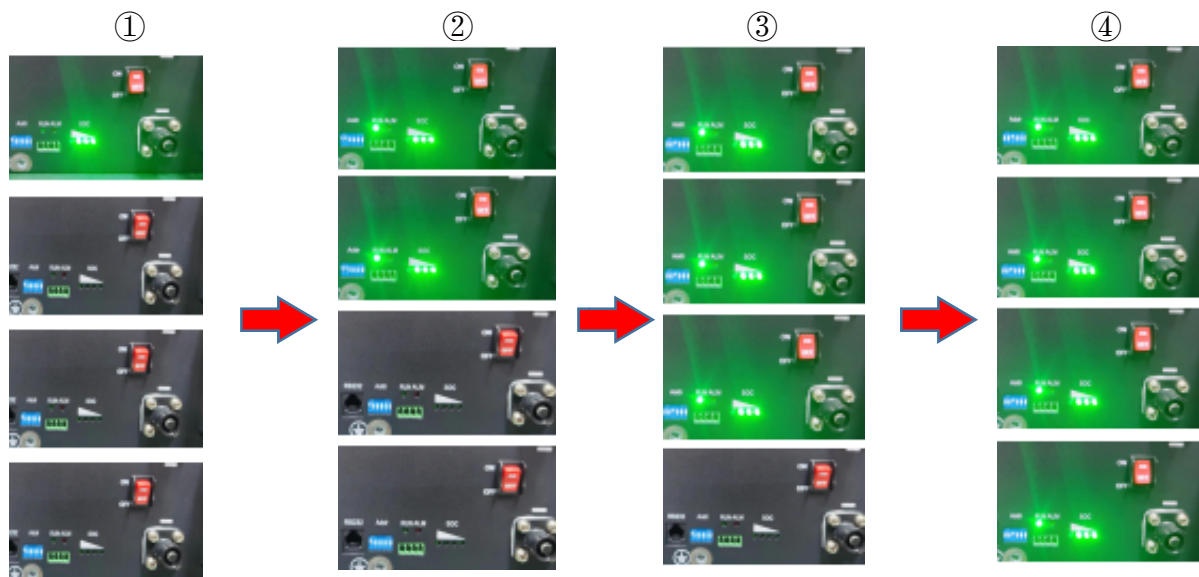

If all the battery LED lights on, and then off, which means the battery system is good and working.



NOTE: After installation, do not forget to register online for full warranty: <http://www.zruipower.com>

NOTE:

- To avoid current pulse of the inverter add on the battery bank. Shall start inverter first or switch on breaker between battery and inverter after all connected batteries turned on.
- Between battery bank and inverter should install breaker to protect system safety.
- All the installation and operation must follow local electric standard.

7. Trouble Shooting Steps

7.1. Problem determination based on

- 1) Whether the battery can be turned on or not;
- 2) If battery is turned on, check the red light is off, flashing or lighting;
- 3) If the red light is off, check whether the battery can be charged/discharged or not.

7.2. Preliminary determination steps

- 1) Battery cannot turn on, switch on the lights are all no lighting or flashing. If the battery external switch is ON, the RUN light is flashing, and the external power supply voltage is 48V or more, the battery still unable to turn on, please contact distributor.
- 2) The battery can be turned on, but red light is lighting, and cannot charge or discharge. If the red light is lighting, that means system is abnormal, please check values as following:
 - a) Temperature: Above 55 or under -10, the battery could not work.
Solution: to move battery to the normal operating temperature range between -5 and 55
 - b) Current: If current is greater than 130A, battery protection will turn on.
Solution: Check whether current is too large or not, if it is, to change the settings on power supply side.
 - c) High Voltage: If charging voltage above 57V, battery protection will turn on.
Solution: Check whether voltage is too high or not, if it is, to change the settings on power supply side.
 - d) Low Voltage: When the battery discharges to 44V or less, battery protection will turn on.
Solution: Charge the battery for some time, the red light turn off

Excluding the four points above, if the faulty is still cannot be located, turn off battery and repair.

7.3. The battery cannot be charged or discharged

- 1) Cannot be charged:

Disconnect the power cables, measure voltage on power side, if the voltage is 53~54V, restart the battery, connect the power cable and try again, if still not work, turn off battery and contact distributor .

- 2) Unable to discharge:

Disconnect the power cables and measure voltage on battery side, if it is under 44V, please charge the battery; if voltage is above 48V and still cannot discharge, turn off battery and contact distributor.

8. Storage, Transportation and Emergency Situations

8.1. Storage

Recharge and maintain the battery pack regularly every three months to ensure the battery is in the best condition.

8.2. Transportation

Battery packs need to be packed before they can be shipped, during transportation, severe impact, extrusion, direct sunlight and rain should be protected.

8.3. Emergency Situations

(1). Leaking Batteries

If the battery pack leaks electrolyte, avoid contact with the leaking liquid or gas. If one is exposed to the leaked substance, immediately perform the actions described below. Inhalation: Evacuate the contaminated area, and seek medical attention.

Contact with eyes: Rinse eyes with flowing water for 15 minutes, and seek medical attention.

Contact with skin: Wash the affected area thoroughly with soap and water, and seek medical attention.

Ingestion: Induce vomiting, and seek medical attention. 2)

(2). Fire

NO WATER! Only dry powder fire extinguisher can be used; if possible, move the battery pack to a safe area before it catches fire.

(3). Wet Batteries

If the battery pack is wet or submerged in water, do not let people access it, and then contact ZRGP or an authorized dealer for technical support.

(4). Damaged Batteries

Damaged batteries are dangerous and must be handled with the utmost care. They are not fit for use and may pose a danger to people or property. If the battery pack seems to be damaged, pack it in its original container, and then return it to ZRGP or an authorized dealer.

NOTE:

- Damaged batteries may leak electrolyte or produce flammable gas.
- In case a damaged battery needs recycling, it shall follow the local recycling regulation (ie. Regulation (EC) N° 1013/2006 among European Union) to process, and using the best available techniques to achieve a relevant recycling efficiency.
- Any further questions, please contact ZRGP: info@zruipower.com



ZHONGRUI GREEN ENERGY TECHNOLOGY (SHENZHEN) CO., LTD.
ADD: 23RD FLOOR, BLOCK B, ZHIHUI JIAYUAN, 76 BAOHE AVENUE,
BAOLONG COMMUNITY, BAOLONG STREET, LONGGANG DISTRICT,
SHENZHEN, CHINA.

Tel: +86 755-2830 6456

Fax: +86 755-8450 6755

Email: info@zruipower.com

Official website: www.zruipower.com

Postcode: 518100